

# Hendricks QRP Kits

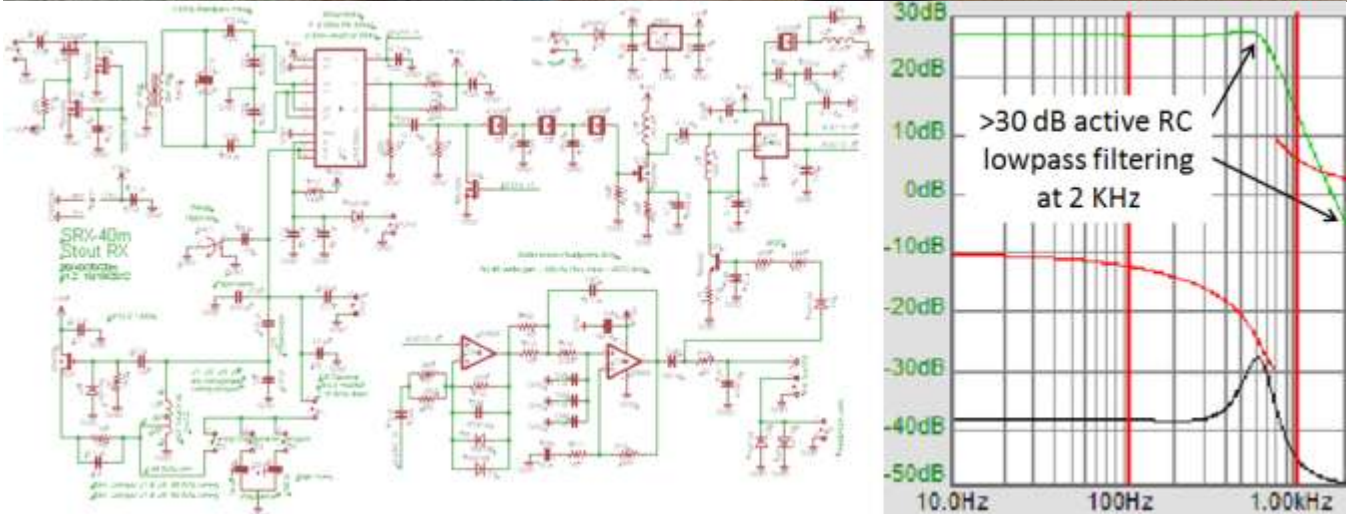

## Simple Receiver (SRX)

Inexpensive CW Receiver for 30 and 40m  
Superhet receiver with high level mixer, AGC, and active R/C audio filtering

by Dan Tayloe, N7VE

## *Table of Contents*

Receiver .....	4
Building the Kit.....	5
Things you will need.....	5
Parts List .....	7
Tools and Construction Hints .....	10
Bare PC Board Pictures .....	11
Installation of Main Tuning and Band Segment Switch.....	12
Installation of the resistors part 1 .....	15
Installation of the resistors part 2.....	18
Installation of the capacitors part 1 .....	21
Installation of the capacitors part 2.....	23
Installation of the capacitors part 3.....	25
Installation of band specific Rs and Cs.....	28
Installation of Inductors .....	30
Installation of misc items, part #1 .....	34
Installation of misc items, part #2.....	39
Installation decals on chassis .....	41
Installation of receiver into chassis.....	42
VFO alignment.....	46

## *List of Figures*

Figure 1. Working over an oversized cookie sheet is highly recommended .....	5
Figure 2. A temperature controlled soldering helps a lot.....	6
Figure 3. A very pointed soldering iron tip is a big help for small components .....	6
Figure 4. Headband Magnifiers. “Mag-eyes” from JoAnn Fabrics .....	7
Figure 5. Top side view of the SRX PC board .....	11
Figure 6. Overlay of the PCB with band segment switch and main tune polyvaricon cap .....	12
Figure 7. Temporarily mount PCB in chassis.....	12
Figure 8. Prepare the leads of the main tuning capacitor.....	13
Figure 9. Mount the main tuning cap to the front panel .....	13
Figure 10. Solder main tuning cap leads from the top side of the PCB.....	13
Figure 11. PCB with main tuning cap and band segment switch installed.....	14
Figure 12. Example of overlay resistors vs. PCB mounted resistors.....	15
Figure 13. Resistors are mounted vertically, with short leads, body on the circle, close to the PCB.....	16
Figure 14. First set of resistors installed .....	16
Figure 15. Resistors installed in this section.....	17
Figure 16. PCB with first set of resistors installed .....	17
Figure 17. Overlay for the next set of resistors plus some diodes .....	18
Figure 18. Picture of resistors installed in this section .....	18
Figure 19. Match 1N4148 diode band with board diode band .....	19
Figure 20. All 1N4148 diodes shown as mounted on the PCB .....	19

Figure 21. PCB with all the resistors installed.....	20
Figure 22. Overlay for the first set of installed capacitors.....	21
Figure 23. Capacitor markings for the first set of capacitors installed .....	21
Figure 24. PCB with first set of capacitors installed .....	22
Figure 25. Overlay of the installation of second set of capacitors.....	23
Figure 26. Markings on the second set of capacitors to be installed .....	23
Figure 27. Lead form the 470 pf polystyrene caps and mount vertically as shown .....	24
Figure 28. PCB with second set of capacitors installed.....	24
Figure 29. Overlay of third capacitor set plus misc parts .....	25
Figure 30. Parts installed in this pass. Xtals, power diode, 5v reg, trim cap, 10 uf cap .....	25
Figure 31. D1 details. Note diode band orientation! Use trimmed leads for 12v input.....	26
Figure 32. PCB with crystals, diodes regulators, and part # 3 caps. 40m version shown. ....	27
Figure 33. PCB with band specific Rs and Cs installed. 40m version shown. ....	29
Figure 34. Overlay of PCB showing inductor placement (with JFETs).....	30
Figure 35. JFET transistors, 1000/100 mH molded chokes, and VFO T37-2 core .....	30
Figure 36. Lead forming and mounting of molded chokes L2, L3, and L10.....	31
Figure 37. Band specific jumpers installed. 40m jumpers shown. ....	31
Figure 38. VFO coil L9. 40m version shown. ....	32
Figure 39. PCB with Inductors (and JFETs) installed .....	33
Figure 40. Overlay of the installation of misc items, part 1 .....	34
Figure 41. Picture of parts installed this in this section .....	34
Figure 42. Keep all transistors close to the PCB (short leads!) .....	35
Figure 43. Notches on ICs line with outline on the PCB.....	35
Figure 44. Lead forming for C45.....	35
Figure 45. L1 transformer. 40m shown: 29T primary, 3T secondary.....	36
Figure 46. Primary and secondary winding connections of L1 to the board shown. 40m shown. ....	36
Figure 47. Board with misc items part # 1 installed. ....	37
Figure 48. Temporary installation of volume pot and headphone jack for testing .....	38
Figure 49. Overlay showing the last board mounted parts .....	39
Figure 50. NE602 and 2N4401 parts shown.....	39
Figure 51. Installation of NE602. Match part and part outline notches.....	40
Figure 52. Completed receiver board.....	40
Figure 53. Visualization of PCB to chassis connections .....	42
Figure 54. Mount PCB in case using four 4-40 screws .....	42
Figure 55. Installation of main tuning hardware.....	43
Figure 56. Mounting of the headphone jack .....	43
Figure 57. Wiring of the headphone jack and volume control to the PCB.....	43
Figure 58. Volume control pot mounted to the front panel .....	44
Figure 59. Mounting of the antenna connector. ....	44
Figure 60. Connection of the 12v power jack to the PCB. ....	45
Figure 61. Front and rear panel views with the mounted hardware (Headphones not included). ....	45
Figure 62. Picture main tune set to the lowest frequency, band segment switch set to low freq .....	46
Figure 63. View of VFO area and L1 front end area .....	47
Figure 64. Picture of L9 with compressed and expanded windings for VFO fine tuning .....	48
Figure 65. Trimmer caps on this particular polyvaricon.....	49
Figure 66. Trim cap to peak receiver front end .....	50

## Specifications and Features

As measured from current prototypes, some variance in performance is expected from unit to unit.

### ***Receiver***

**Receiver Type:** Superhet with a three crystal IF filter

**Receiver sensitivity:** Better than -120 dBm

**Current Drain:** ~ 17 mA at 12v.

### **Features:**

- Bus switch first mixer improves handling of high level signal (40m SWBC!)
- AGC – Automatically reduces large signals
- 3 pole Crystal filter
  - Single sided receiver reception
  - Wider 500 Hz filter decreases “ringing” and listener fatigue
- Audio gain chain incorporates active R/C low pass filter
  - Reduces unwanted high frequency audio gain stage hiss
  - Provides >30 dB additional attenuation for signals more than 2KHz away
- Headphone level output with diode limiting –
  - Protects your ears from static crashes or sudden strong stations
- Band coverage provided in two ranges
  - Each tuning range ~ 20 KHz wide
  - On board switch selects upper or lower band segments
    - 40m covers 7.000 to 7.022 and 7.024 to 7.049 MHz (DX and QRP segments)
    - 30m covers 10.100 to 10.120 MHz
- External “mute” input (active low)
  - Reduces receiver gain by ~ 70 dB
  - Receiver input protected to 5w when muted (only when muted!)

## ***Building the Kit***

### ***Things you will need***

- Solder sucker (highly recommended) or solder wick
- Temperature control soldering iron with a fine tip
- Magnifying headpiece and/or magnifying glass. 3.5 power reading glasses may work also. Try them on and check for focus at a 6 to 8" operating distance.
- Cookie sheet (highly recommended for building on top of in order to catch stray parts and most importantly to reduce **static discharge damage** to parts.

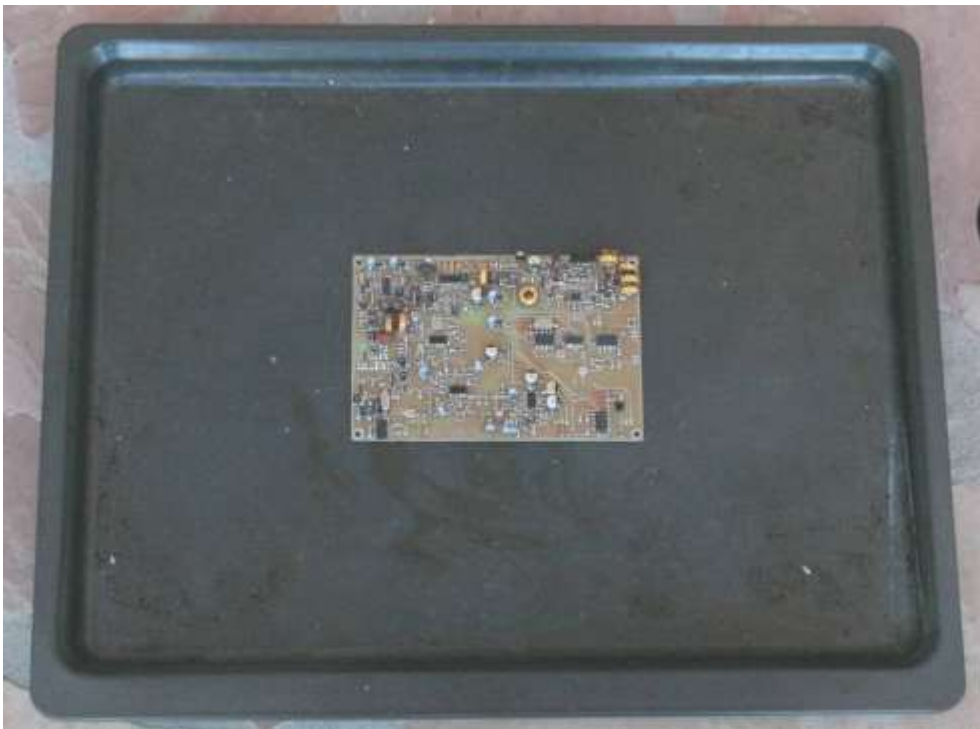

**Figure 1. Working over an oversized cookie sheet is highly recommended**





**Figure 2. A temperature controlled soldering helps a lot.**



**Figure 3. A very pointed soldering iron tip is a big help for small components**



**Figure 4. Headband Magnifiers. “Mag-eyes” from JoAnn Fabrics**

As far as magnification, I think that common reading glasses may be just as good. Try 3.5 or 3.25 magnification glasses. Try them on and check the focus distance. Ideal is a focus distance of about 8 inches.

I use the above Mag-eyes with my normal 1.5x reading glasses. I can gang both the reading glasses and the Mag-eyes together to get a really good, close up look at the parts. However, it does drive my eyes a bits nuts switching from no glasses to glasses, to Mag-eyes, to glasses plus Mag-eyes.

### ***Parts List***

Below is a list of the all parts that are included in the kit:

**Table 1. Inventory of band generic parts**

Capacitor list		
Quantity	Value	Devices
1	2.2 pf NPO	C11
1	150 pf NPO	C33
1	270 pf NPO	C6
2	470 pf	C19, C22
2	470 pf Polystyrene	C9, C10
3	4700 pf	C17, C38, C47
21	0.1 uf	C1, C3, C12, C13, C14, C15, C16, C23, C24, C25, C28, C29, C30, C31, C32, C35, C39, C41, C42, C43, C44
3	10 uf	C36, C40, C48
2	100 uf	C45, C46
1	40 pf trim cap, 6mm	C18
1	Main tuning Polyvaricon	C1

Diode, Transistors and IC list		
Quantity	Value	Devices
1	1N5817	D1
7	1N4148	D3, D4,D5, D6, D7, D8, D11
1	74HC4053	IC1
1	78L05	IC2
1	NE602	IC3
1	LM833	IC4
2	2N5485	Q4, Q7
1	2N4401	Q6
4	2N7000	Q1, Q2,Q3, Q5

Resistor list		
Quantity	Value	Devices
1	22	R15
3	390	R9, R21, R23
6	1K	R2, R7, R11, R13, R18, R22
1	3.9K	R14
5	22K	R5, R6, R8, R12, R19
2	47K	R3, R10
3	100K	R1, R4, R17
1	1K panel mount (volume)	J6



Inductor list		
Quantity	Value	Devices
1	T37-2	L9
1	100 uH molded choke	L10
1	1000 uH molded choke	L3

Case hardware list		
Quantity	Value	Devices
1	CHASSIS	
4	4-40 x .25 Pan HEAD SCREW	
1	Small NORCAL KNOB	
1	Large NORCAL KNOB	
4	RUBBER FEET, 1/4" THICK	

Misc hardware list		
Quantity	Value	Notes
1	Hole plug – unused rear hole	
1	1/8th stereo jack – Keyer paddles/Key input	
1	BNC antenna jack (with ground lug, lock washer, and nut)	
1	Panel Mount Power Jack	
2	Polyvaricon mounting screw	
1	Polyvaricon 1/4" nylon shaft	
1	Polyvaricon shaft screw	
1	3 feet # 32 gauge wire	
1	2 feet # 28 gauge wire	
1	12 inches hook up wire	
1	PC board	
1	Sub mini slide switch	
1	Decal Sheet	

**Table 2. Band Specific Part Values**

	C2	C4	C5	C20	C21	C26	C27	C34
30m	22 pf	22 pF	56 pF	680 pf	680 pf	220 pf	220 pf	220 pf
40m	27 pf	27 pF	68 pF	470 pf	470 pf	150 pf	150 pf	270 pf

	L1	L2	R16	Y1,Y2,Y3,Y4
30m	T37-6 (yellow core)	10 uH molded choke	220	7.37 MHz series crystal
40m	T37-2 (red core)	33 uH molded choke	390	4.915 MHz series crystal

## ***Tools and Construction Hints***

In building this transceiver as well as others, I have had some problems. These fall into several different categories:

- 1) ICs mounted backwards
- 2) Resistors and capacitors not soldered to the right pads (***#2 most common problem!***)
- 3) Diodes installed backwards
- 4) Not all parts were installed
- 5) Leads not totally stripped on the toroid cores (***#1 most common problem!***)

Please learn from my mistakes. Each time an IC is mounted, check the mounting polarity twice before soldering it in. I suggest checking the IC polarity, soldering down one corner pin, and then checking it one more time before finishing the job. I think the old saying is “measure twice, cut once.”

I have once been bit by not mounting all the parts. Double check the pictures against your kit to make sure things end up in the right place.

You may find that the components in the pictures may be slightly different from what is in your kit. Parts can change from order to order.

This manual has been set up to build a section, and then test it. The tests are normally quite simple. This should find most problems as we go from stage to stage rather than getting to the end and not knowing where to start.

I found building the transceiver over a large cookie sheet eliminated the problem of dropping parts and losing them. However, when doing the applied voltage tests, you should place a few sheets of clean paper under the boards to keep them from shorting out against the cookie sheet.

***Some parts are static sensitive!*** Please take the suggestion to build over a conductive surface like a large cookie sheet and always touch the cookie sheet before touching any part after leaving and returning to work.

***This receiver can be built in about six hours.***

*Bare PC Board Pictures*

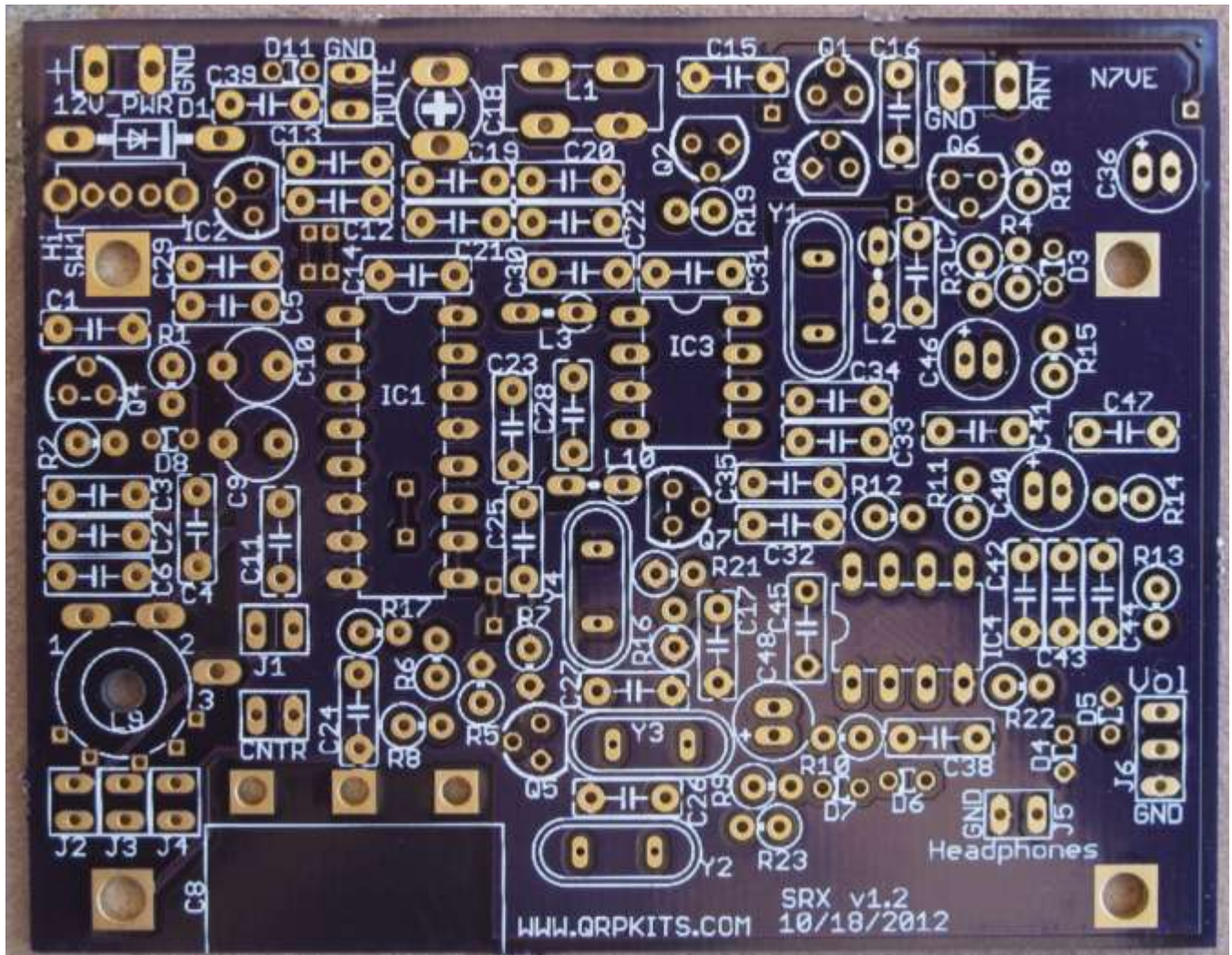

Figure 5. Top side view of the SRX PC board



## Installation of Main Tuning and Band Segment Switch

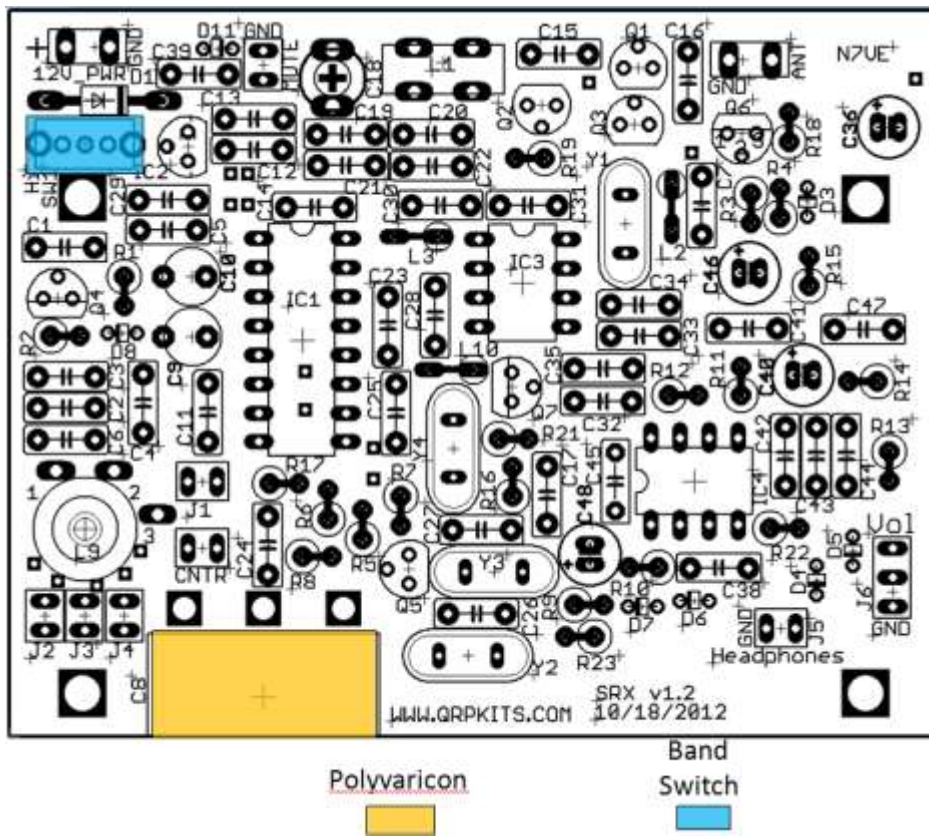

Figure 6. Overlay of the PCB with band segment switch and main tune polyvaricon cap



Figure 7. Temporarily mount PCB in chassis

In order for the main tuning capacitor to be aligned properly, the main tuning capacitor needs to be soldered to the PCB when the PCB is in the chassis and the capacitor is mounted to the front panel.

Mount the PCB in the chassis as shown above. Use all four mounting screws. The PCB will only fit in the chassis one way. Prepare the main tuning capacitor leads by first bending the leads straight back, then forming and trimming them as shown below.



**Figure 8. Prepare the leads of the main tuning capacitor**



**Figure 9. Mount the main tuning cap to the front panel**

The main tuning cap needs to be mounted to the front panel with the main tuning shaft centered as much as possible as shown above.



**Figure 10. Solder main tuning cap leads from the top side of the PCB**



Solder the main tuning cap leads to the top of the board. Then remove the board and capacitor from the chassis and trim the tuning capacitor on the bottom side of the board if needed.

Next mount the band segment switch as shown below.

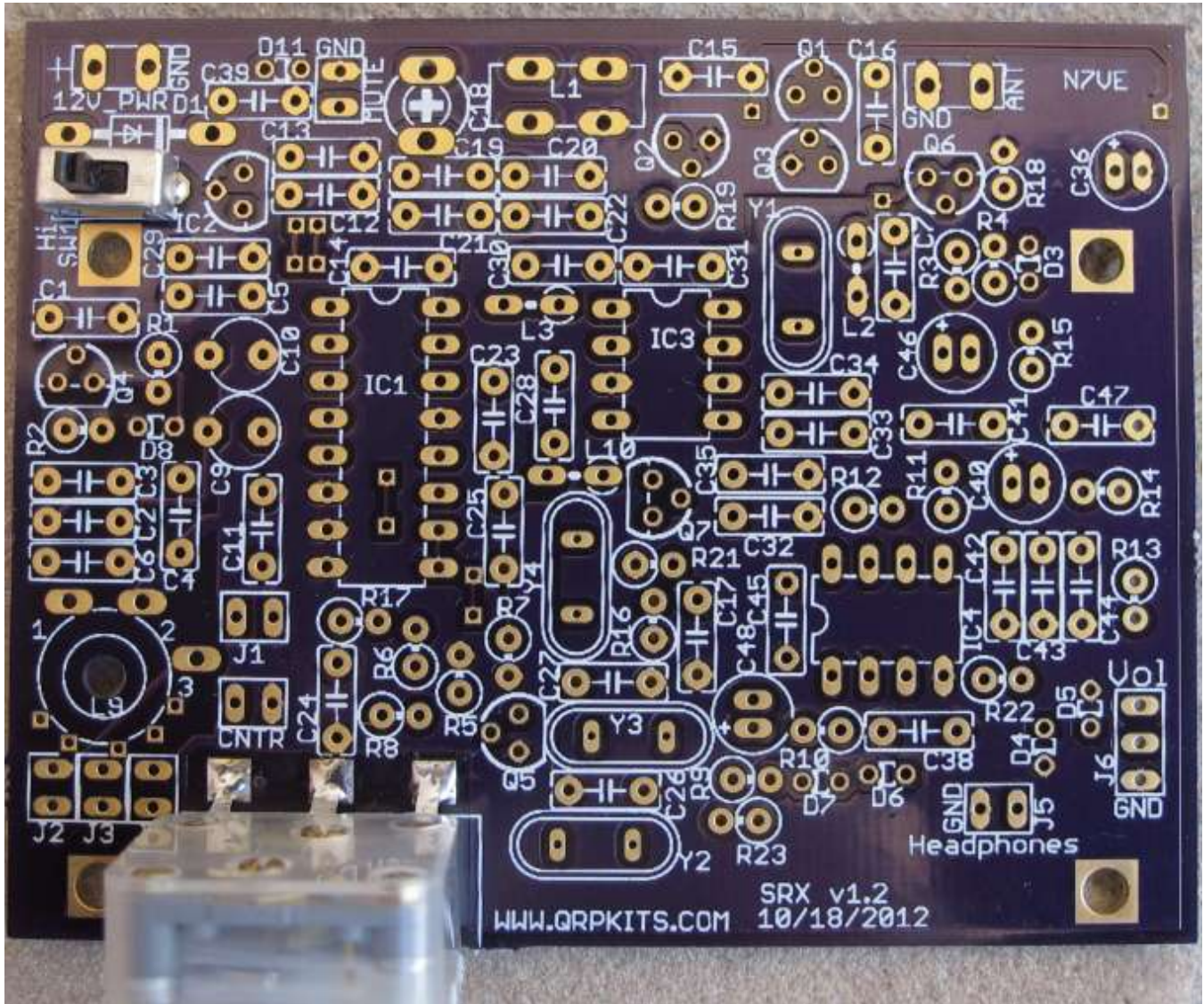

Figure 11. PCB with main tuning cap and band segment switch installed

## Installation of the resistors part 1

**It is very easy to get resistors confused.** 22 and 22K resistors, and 390 and 3.9K resistors are easy to confuse. First start by sorting all the resistors into different piles, one pile for each resistor type. **You can use a volt-ohm meter to double check the resistor values as an additional precaution.**

The seven resistor types in this kit and their associated color codes are:

100K (brown – black – yellow) – 3 resistor total

47K (yellow – violet – orange) – 2 resistor total

22K (red – red – orange) – 5 resistors total

3.9K (orange – white – red) – 1 resistors total

1K (brown – black – red) – 6 resistors total

390 (orange – white – brown) – 3 resistors total

22 (red – red – black) – 1 resistor total

These are the resistors common across all the bands. There are band specific resistors.

All resistors are mounted vertically. The base of the resistor is mounted on the circle portion of PCB symbol, while the direction of the pad for the other lead is indicated by the square on the circle as shown below.

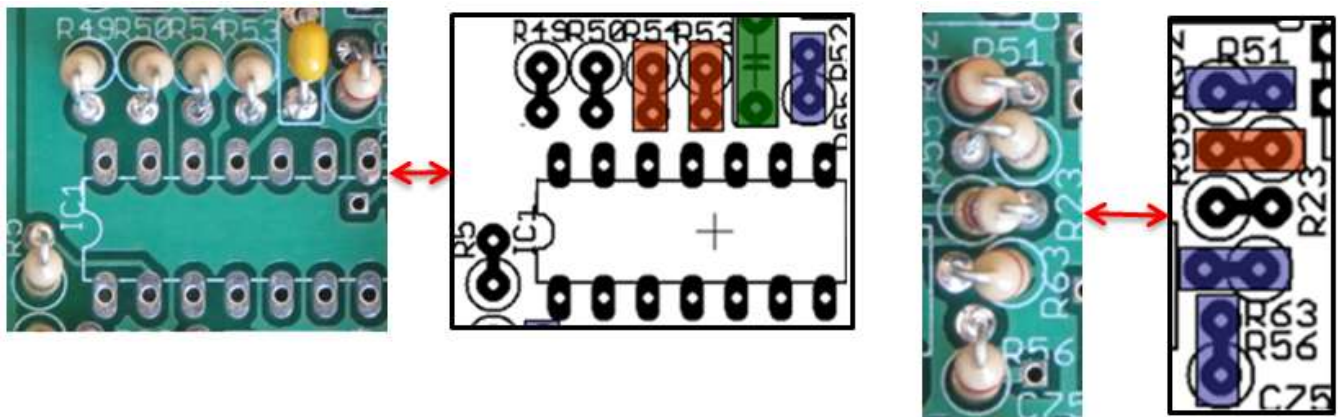

**Figure 12. Example of overlay resistors vs. PCB mounted resistors**

Notice the “Rxx” designation on the overlay diagram and the placement of the real resistors on the board. Again, the resistor body goes on the circle, and the resistor lead goes in the direction of the small square on the circle. Note in particular R48 and R50 in the first drawing and the direction it indicates for the lead side of the resistor. Compare that with the mounted resistor in the photo. Like wise, in the second drawing, R56 at the bottom is pointed North-South (NS) while the other resistors above it are pointed East-West (EW).

The overlay has exaggerated the correct resistor installation direction by the use of a colored rectangle to indicate the proper orientation when a resistor is to be installed in a particular spot.



*It is easy to place a resistor in the wrong spot.* I suggest placing the resistor in the board, spreading the leads outward on the bottom to hold them into place, then double checking the parts placement a second time before soldering the resistors in place and trimming off their leads.



Figure 13. Resistors are mounted vertically, with short leads, body on the circle, close to the PCB

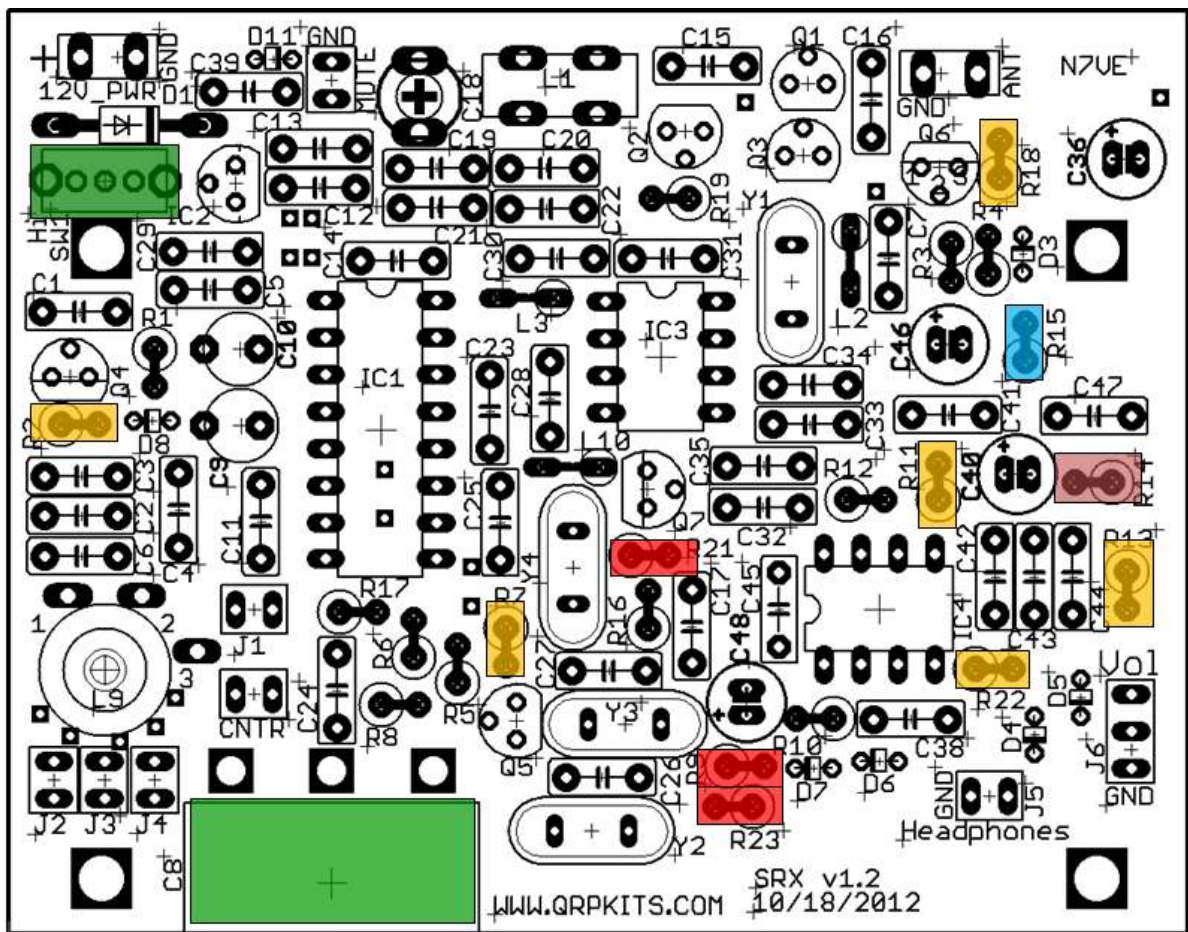





 Already Installed	 22	 390	 1K	 3.9K
---	--	---	--	--

Figure 14. First set of resistors installed



Figure 15. Resistors installed in this section

As the parts are installed, it is recommended to both **check the box** below and **cross off the part on the picture** above. Install the following parts in the following order:

Install 22 resistors (marked red – red – black).  R15

Install 390 ohm resistors (marked orange – white – brown).  R9,  R21,  R23

Install 1K resistors (marked brown-black-red).  R2,  R7,  R11,  R13,  R18,  R22

Install 3.9K resistors (marked orange-white-red).  R14

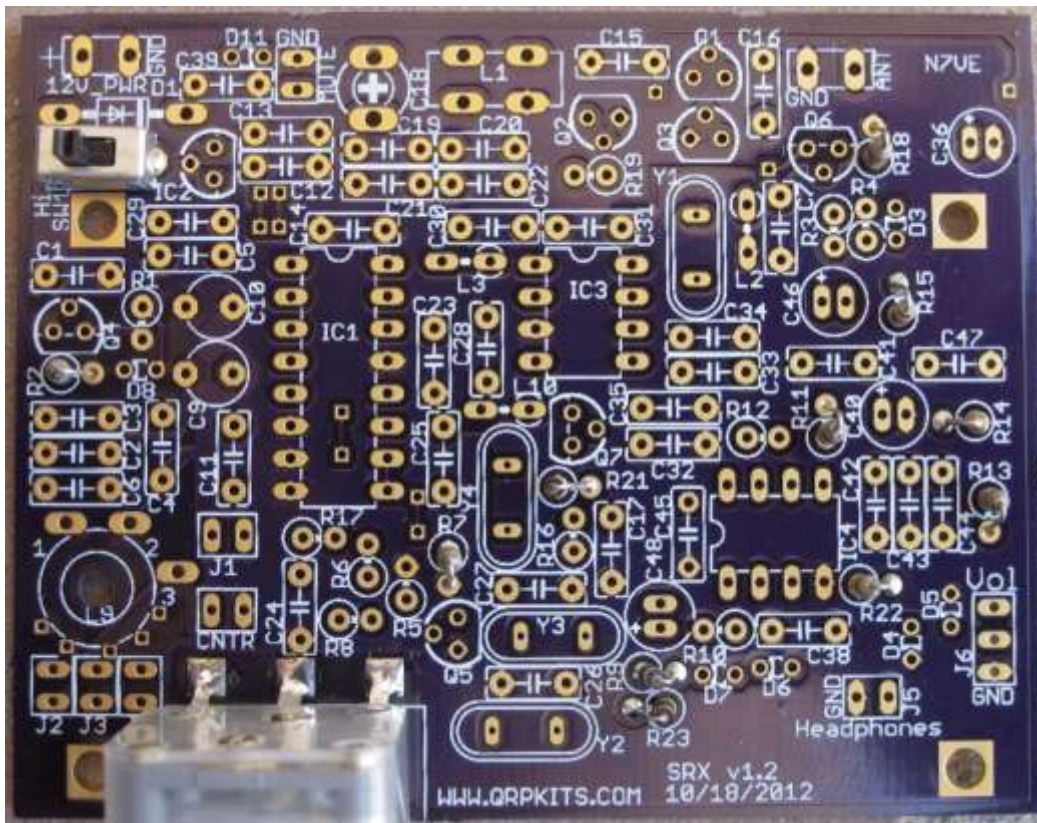

Figure 16. PCB with first set of resistors installed



## Installation of the resistors part 2

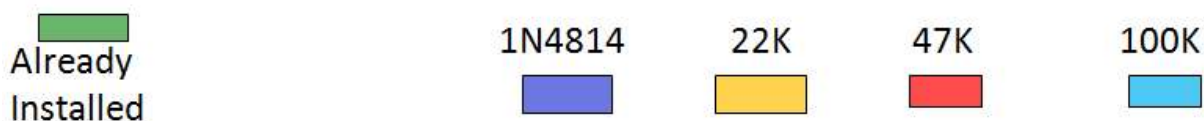
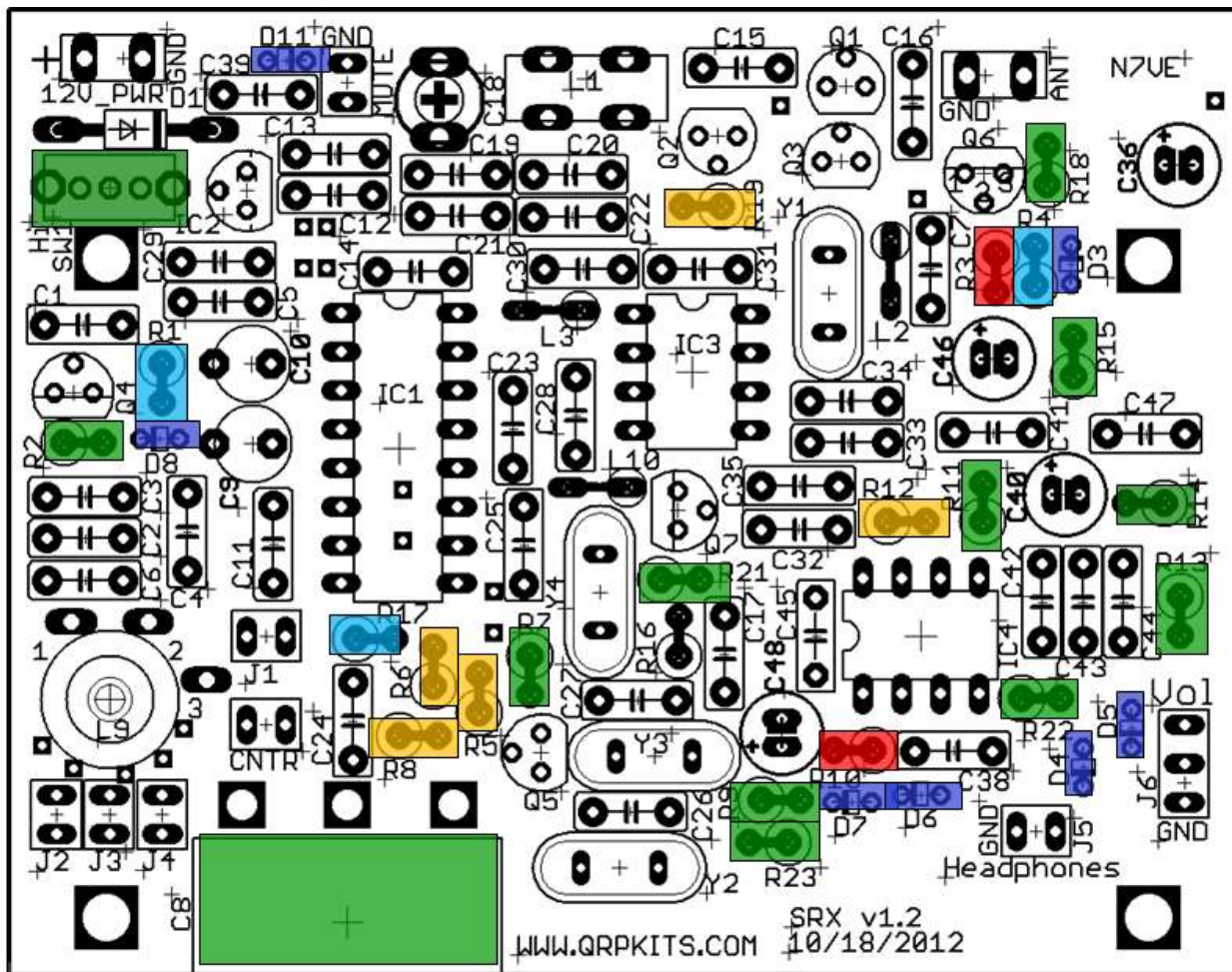

Figure 17. Overlay for the next set of resistors plus some diodes



Figure 18. Picture of resistors installed in this section



As the parts are installed, it is recommended to both *check the box* below and *cross off the part on the picture* above. Install the following parts in the following order:

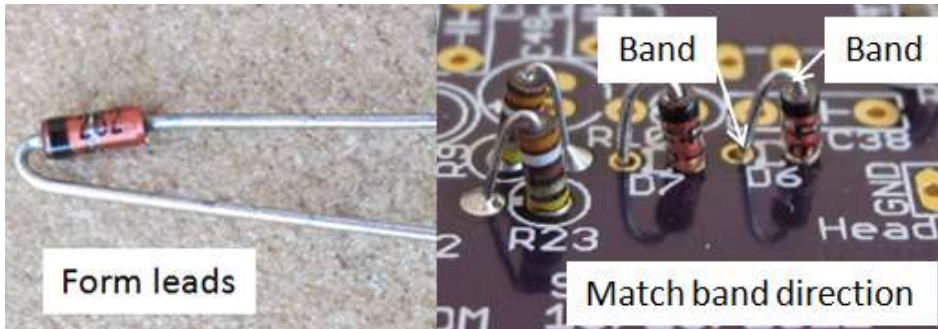

Figure 19. Match 1N4148 diode band with board diode band

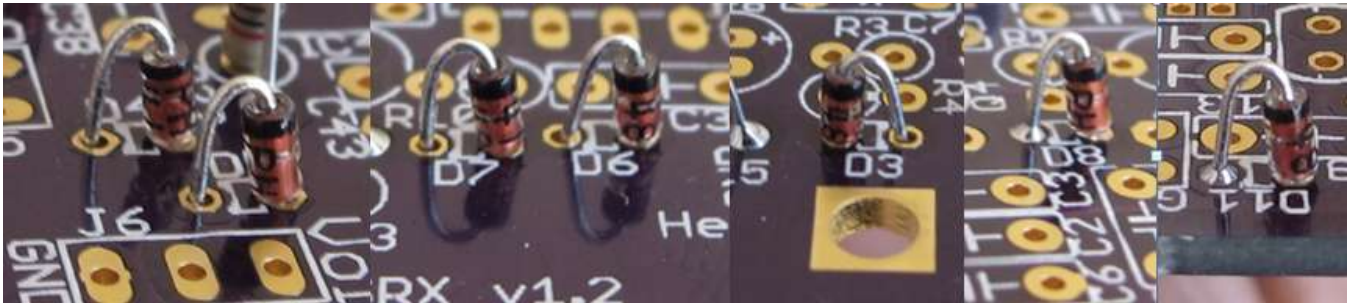

Figure 20. All 1N4148 diodes shown as mounted on the PCB

Install 1N4148 diodes.  D3,  D4,  D5,  D6,  D7,  D8,  D11 Mount the diode vertically as shown above. *Double check the polarity of the diode against the band on the board.*

Install 390 ohm resistors (marked orange – white – brown).  R9,  R21,  R23

Install 1K resistors (marked brown-black-red).  R2,  R7,  R11,  R13,  R18,  R22

Install 3.9K resistors (marked orange-white-red).  R14

All resistors should be installed now except for R16 which is band specific. It will be installed later with other band specific parts.

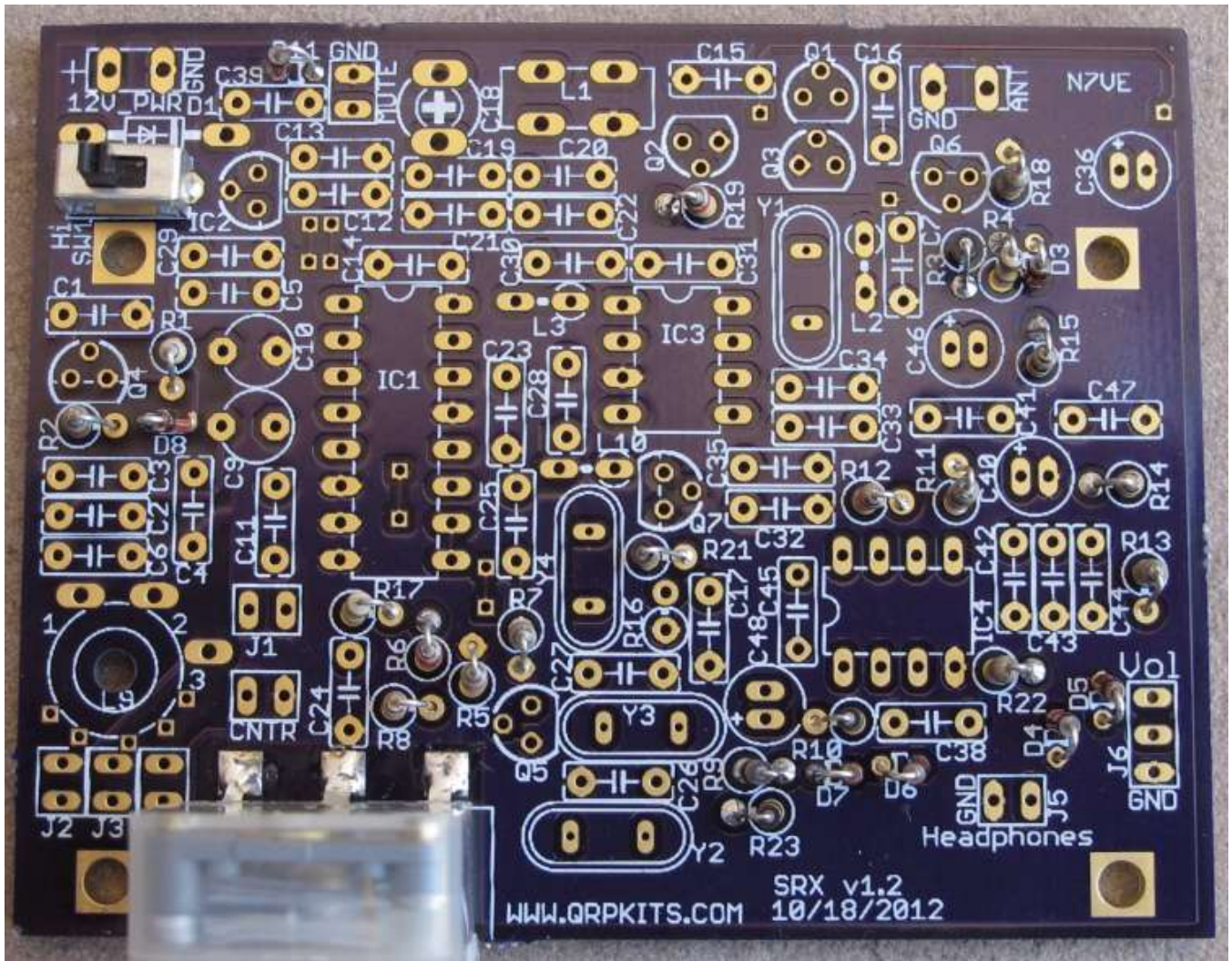

Figure 21. PCB with all the resistors installed



## Installation of the capacitors part 1

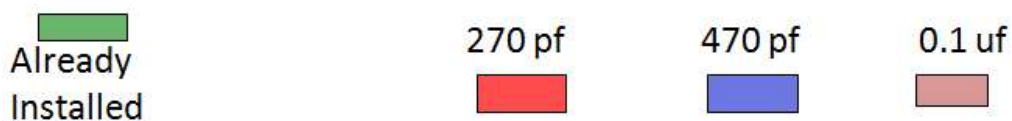
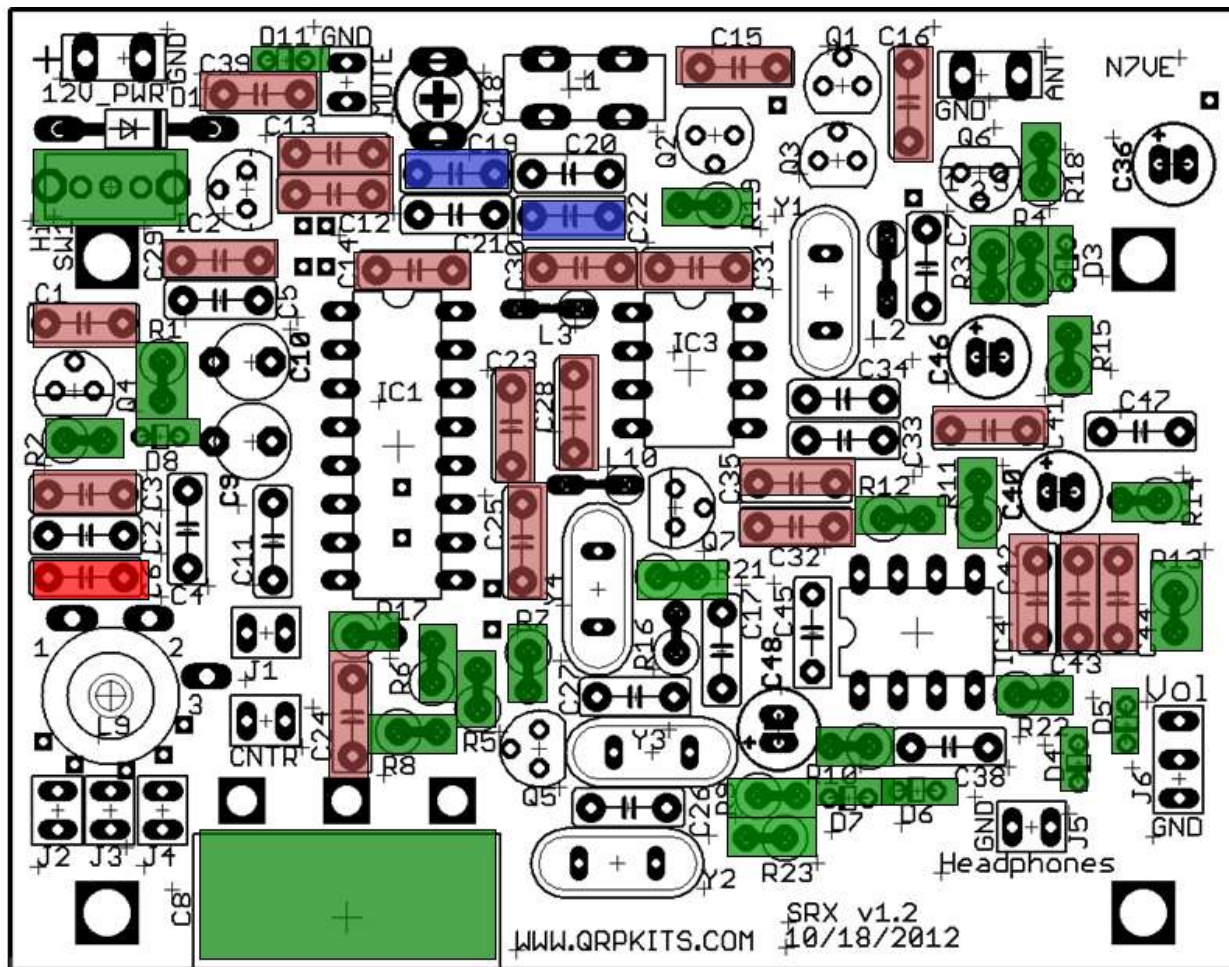

Figure 22. Overlay for the first set of installed capacitors



Figure 23. Capacitor markings for the first set of capacitors installed

As the parts are installed, it is recommended to both **check the box** below and **cross off the part on the picture** above. Install the following parts in the following order:

- Install 270 pf cap (marked “271”) □ C6
- Install 470 pf caps (marked “471”) □ C19, □ C22 **Note: These 470 pf capacitors are flat disc capacitors as shown. They are \*\*\*not\*\*\* the plastic/silver tubular 470 pf polystyrene capacitors that will be installed in the next section.**
- Install 0.1 uf caps (Marked “104”) □ C1, □ C3, □ C12, □ C13, □ C14, □ C15, □ C16, □ C23, □ C24, □ C25, □ C28, □ C29, □ C30, □ C31, □ C32, □ C35, □ C39, □ C41, □ C42, □ C43, □ C44

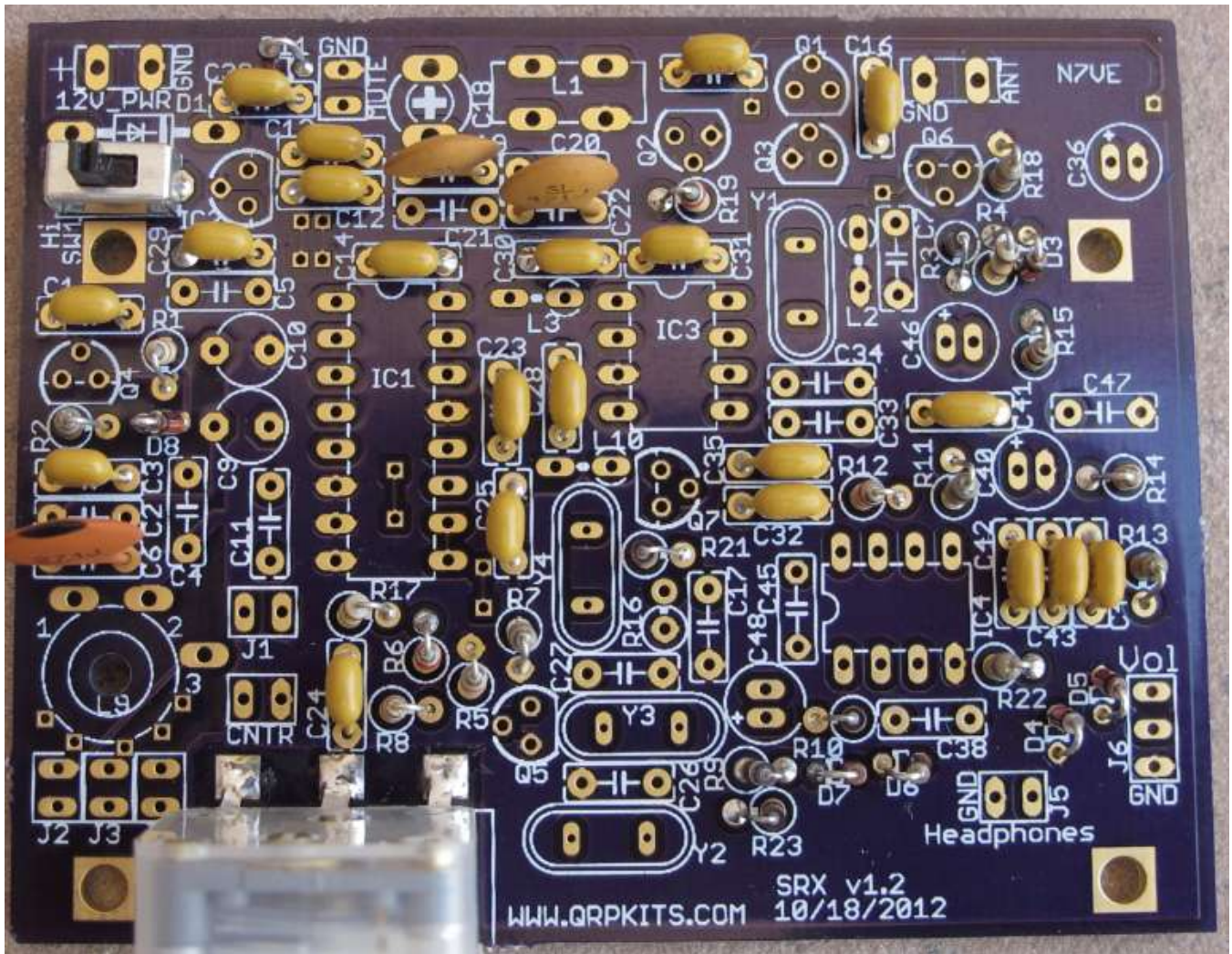

Figure 24. PCB with first set of capacitors installed



## Installation of the capacitors part 2

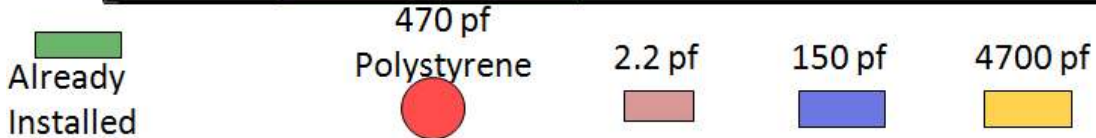
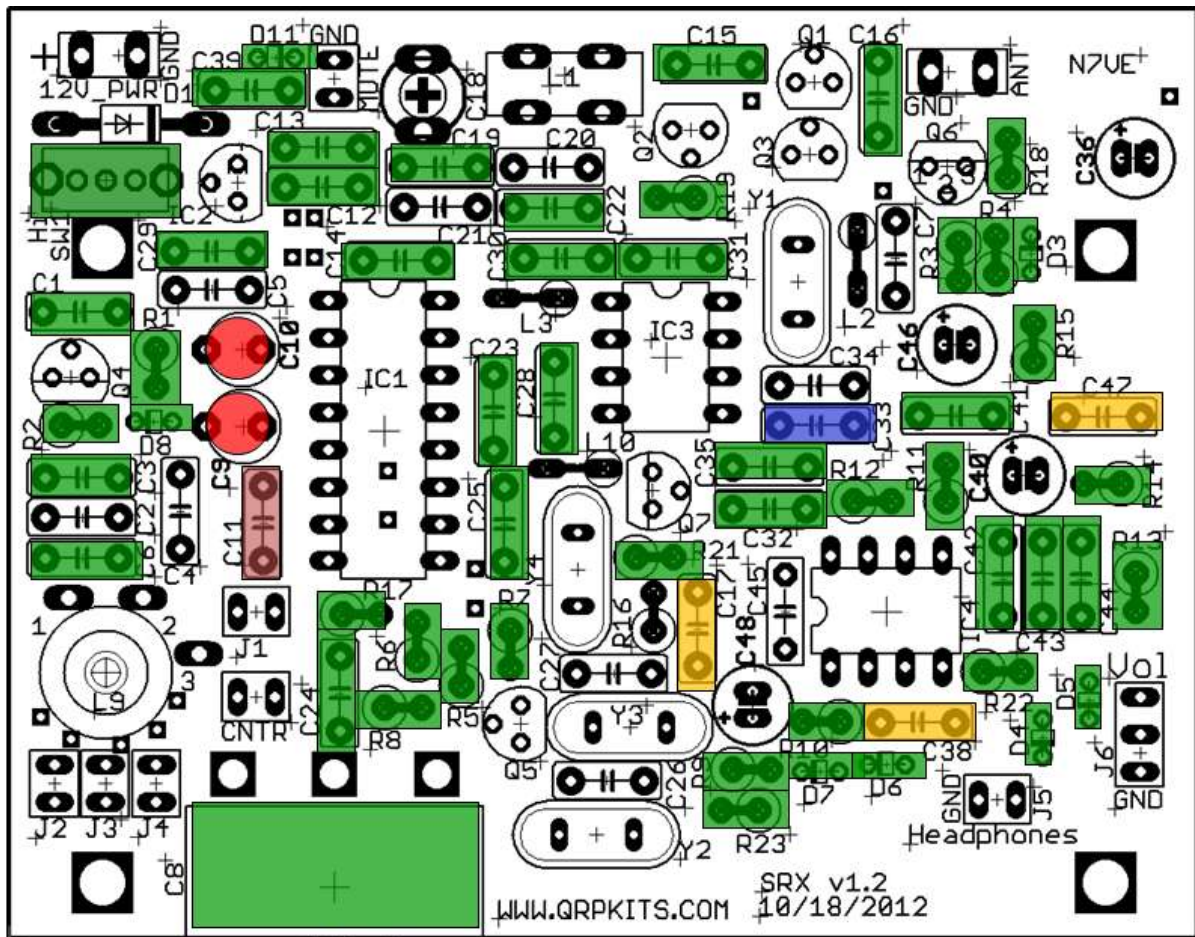

Figure 25. Overlay of the installation of second set of capacitors



Figure 26. Markings on the second set of capacitors to be installed



As the parts are installed, it is recommended to both **check the box** below and **cross off the part on the picture** above. Install the following parts in the following order:

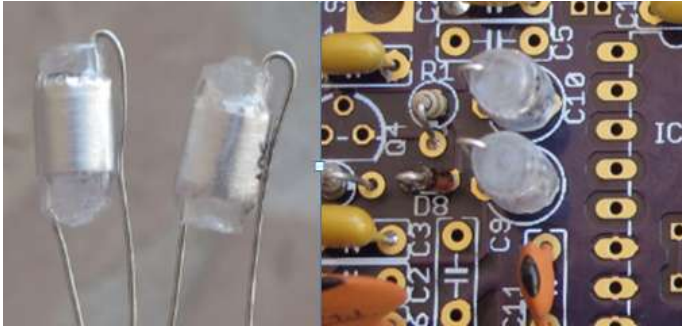

Figure 27. Lead form the 470 pf polystyrene caps and mount vertically as shown

Install 470 pf caps (marked “470”)  C9,  C10 as shown above.

Install 150 pf cap (marked “151”)  C33

Install 2.2 pf cap (marked “2.2”)  C11

Install 4700 pf caps (Marked “472”)  C17,  C38,  C47

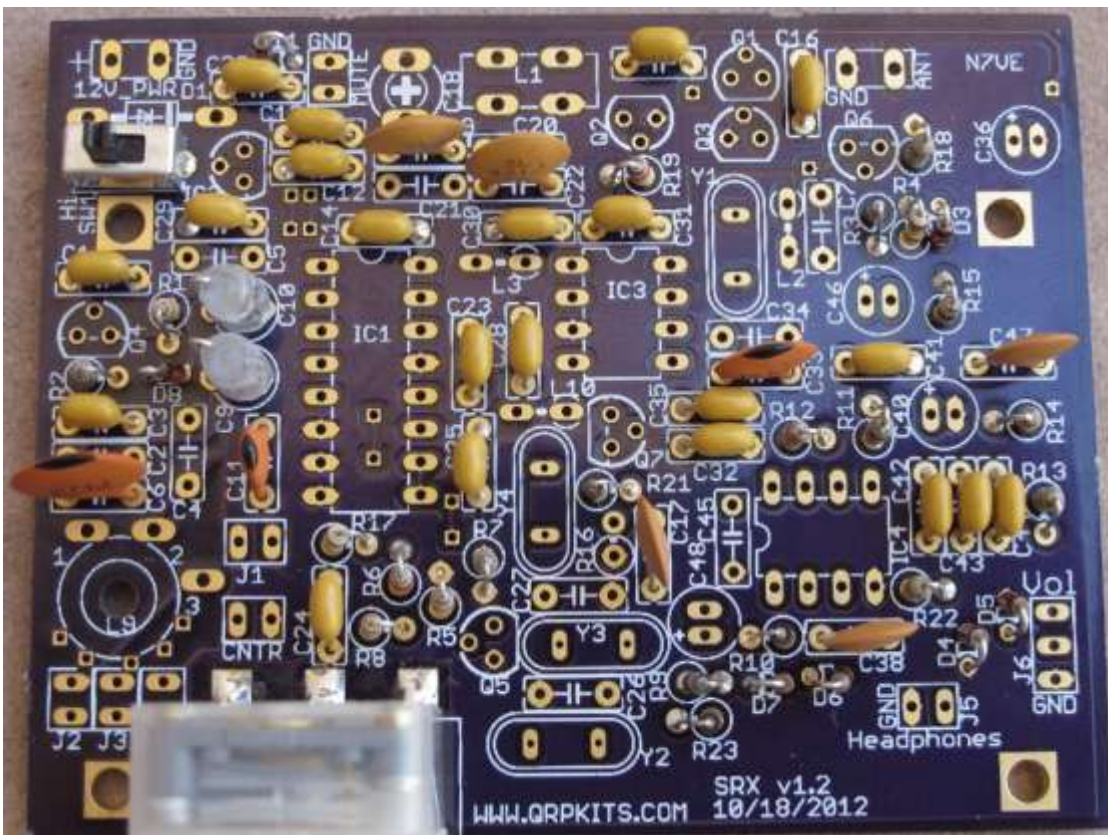

Figure 28. PCB with second set of capacitors installed.

### Installation of the capacitors part 3

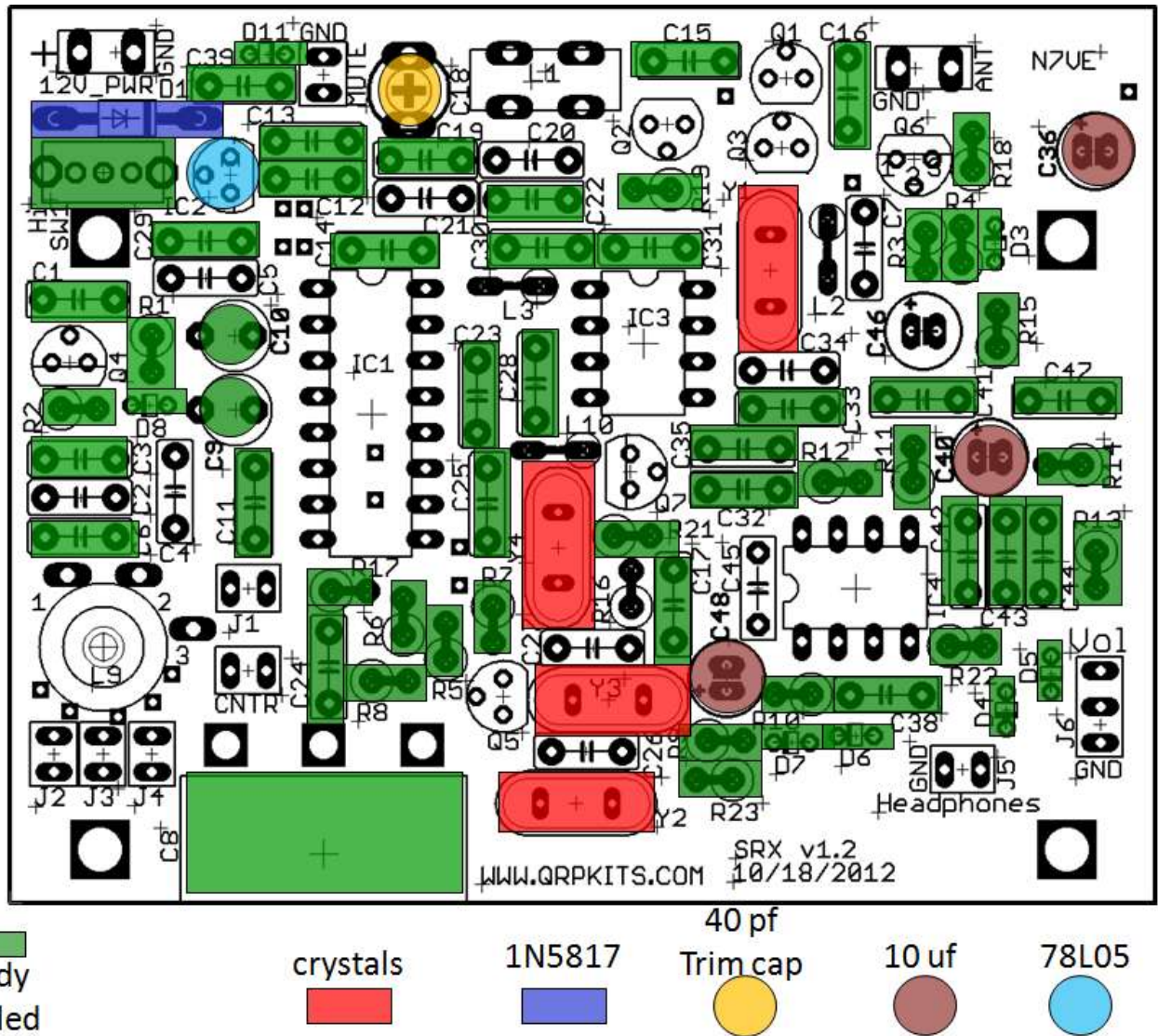

Figure 29. Overlay of third capacitor set plus misc parts

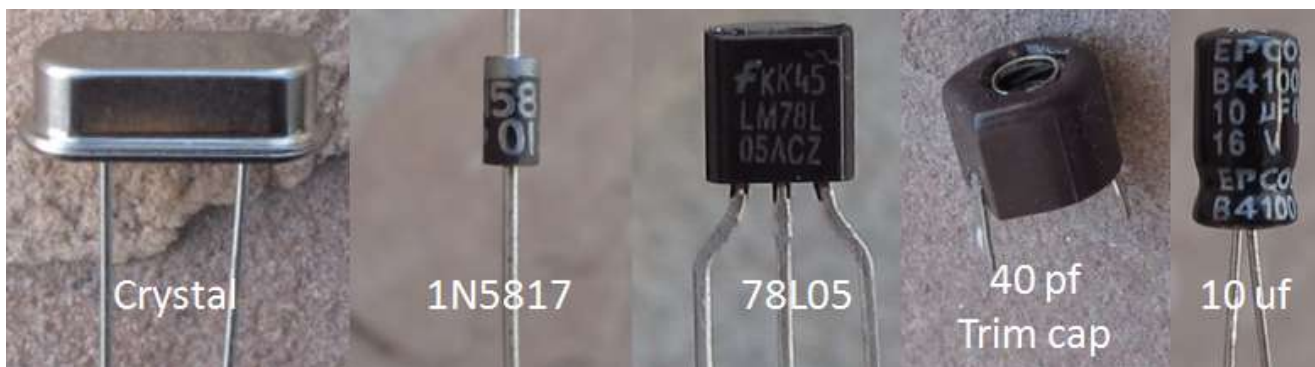
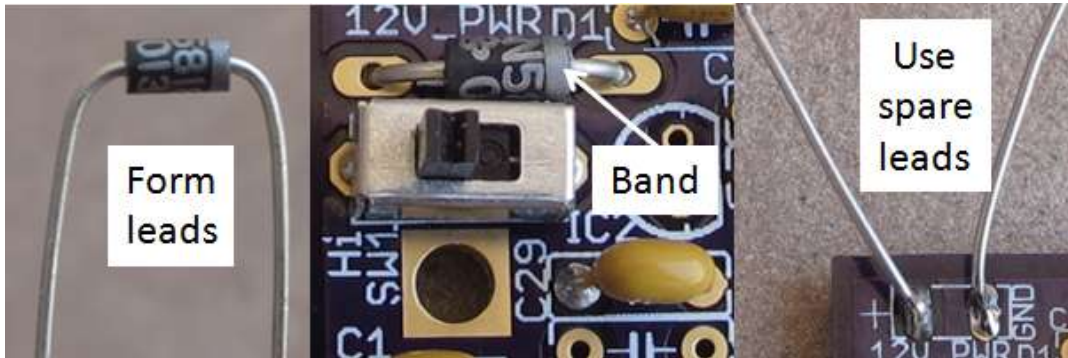

Figure 30. Parts installed in this pass. Xtals, power diode, 5v reg, trim cap, 10 uf cap



As the parts are installed, it is recommended to both **check the box** below and **cross off the part on the picture** above. Install the following parts in the following order:



**Figure 31. D1 details. Note diode band orientation! Use trimmed leads for 12v input**

Install  D1 1N5817. This polarity protection diode is used to protect against connecting the 12v power backwards. See details below. Make sure the banded end connects to the hole as shown on the D1 board markings. **Double check the polarity of the diode against the photos above. Use the trimmed as temporary leads for the input voltage as shown below.**

Install crystals  Y1,  Y2,  Y3,  Y4. 40m uses 4.9152 MHz crystals, 30m uses 7.37 MHz crystals

Install 78L05 5v regulator IC  IC2 **Make sure flat side of the IC lines up with flat side of the PCB outline**

Install 40 pf trim cap  C18

Install 10 uf caps (marked 10 uf)  C36,  C40,  C48 **These caps have a “long” lead and a “short” lead. The long lead is the “+” side of the cap. The long lead needs to go through the cap hole marked with “+” on the board.**

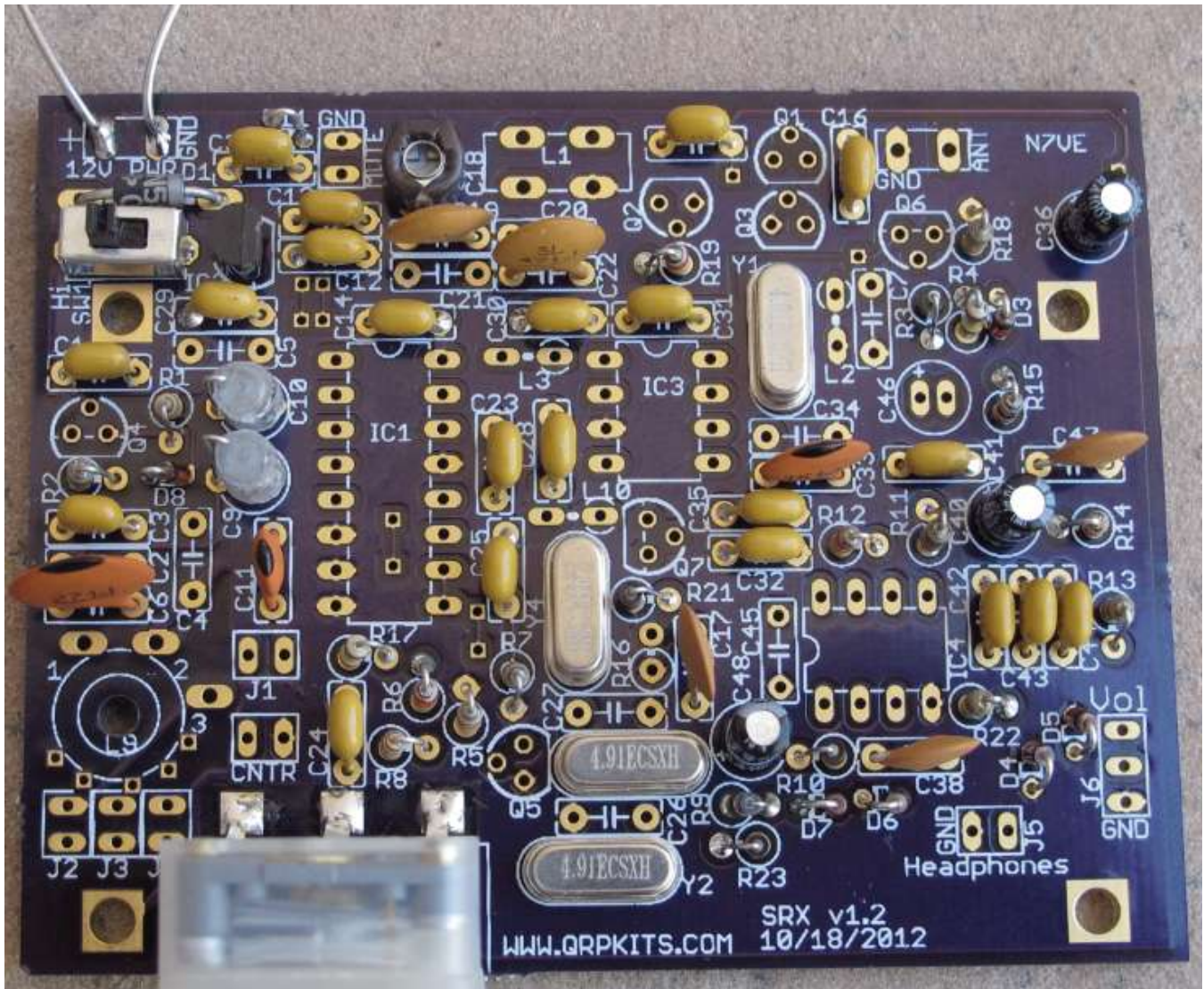
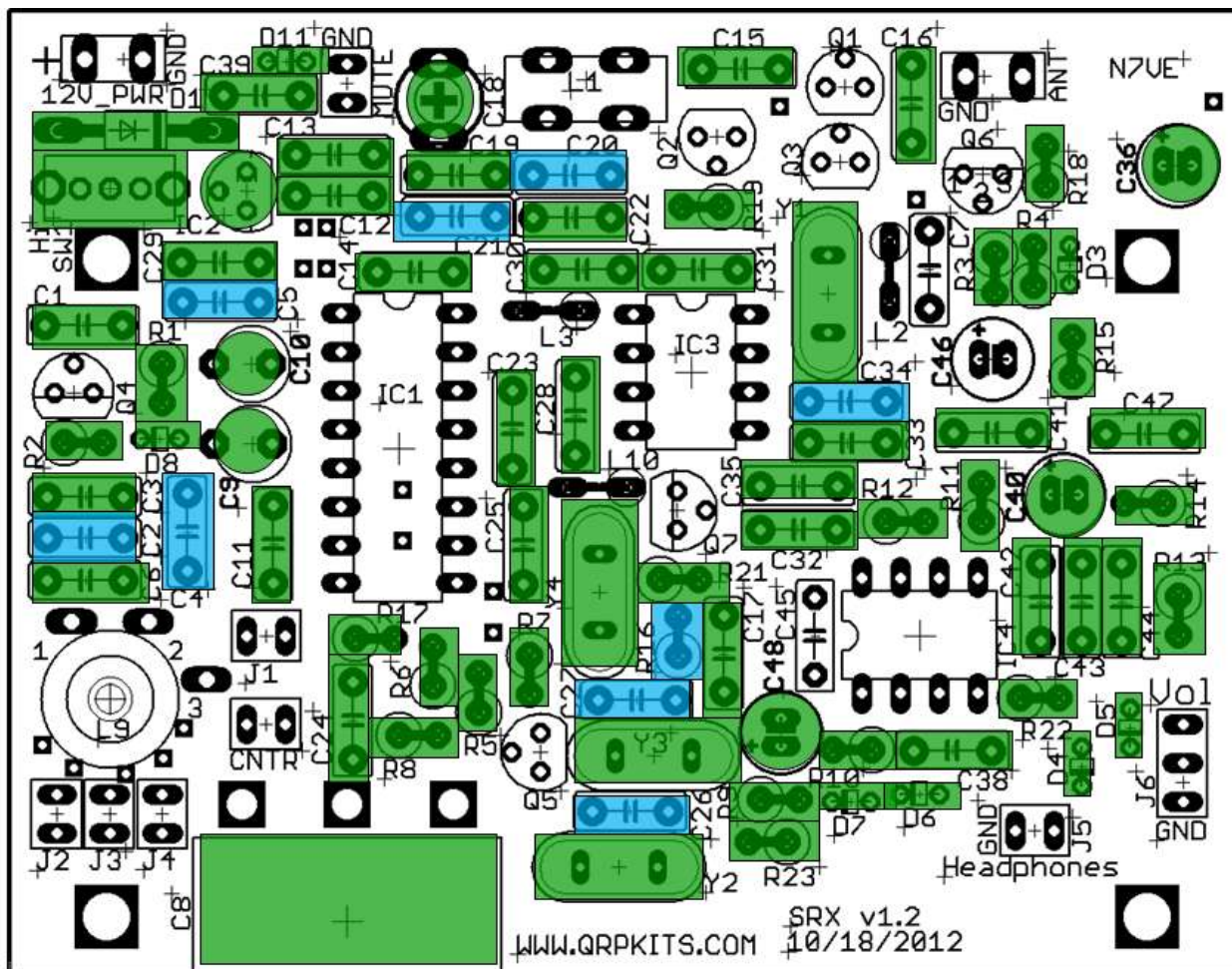

Figure 32. PCB with crystals, diodes regulators, and part # 3 caps. 40m version shown.

□ **Quick test # 1:** Connect 12v to the 12v input power leads. The current drain in this stage is roughly 2.3 mA. At this point, the main current drain is the 78L05 5v voltage regulator. *Disconnect the 12v when done.*



## Installation of band specific Rs and Cs



  
 Already  
 Installed

Left over band  
 specific Rs/Cs  

### 30m parts

Use this list to populate the PCB above if you have the **30m** version on the receiver.

2	22 pf NPO (marked "22")	C2, C4
1	56 pf NPO (marked "56")	C5
3	220 pf NPO (marked "221")	C26, C27, C34
2	680 pf (marked "681")	C20, C21
1	220 resistor marked red-red-brown	R16

## 40m parts

Use this list to populate the PCB above if you have the **40m** version on the receiver.

2	27 pf (marked "27")	C2, C4
1	68 pf (marked "68")	C5
2	150 pf (marked 151")	C26, C27
1	270 pf (marked "271")	C34
2	470 pf (marked "471")	C20, C21
1	390 resistor marked (orange-white-brown)	R16

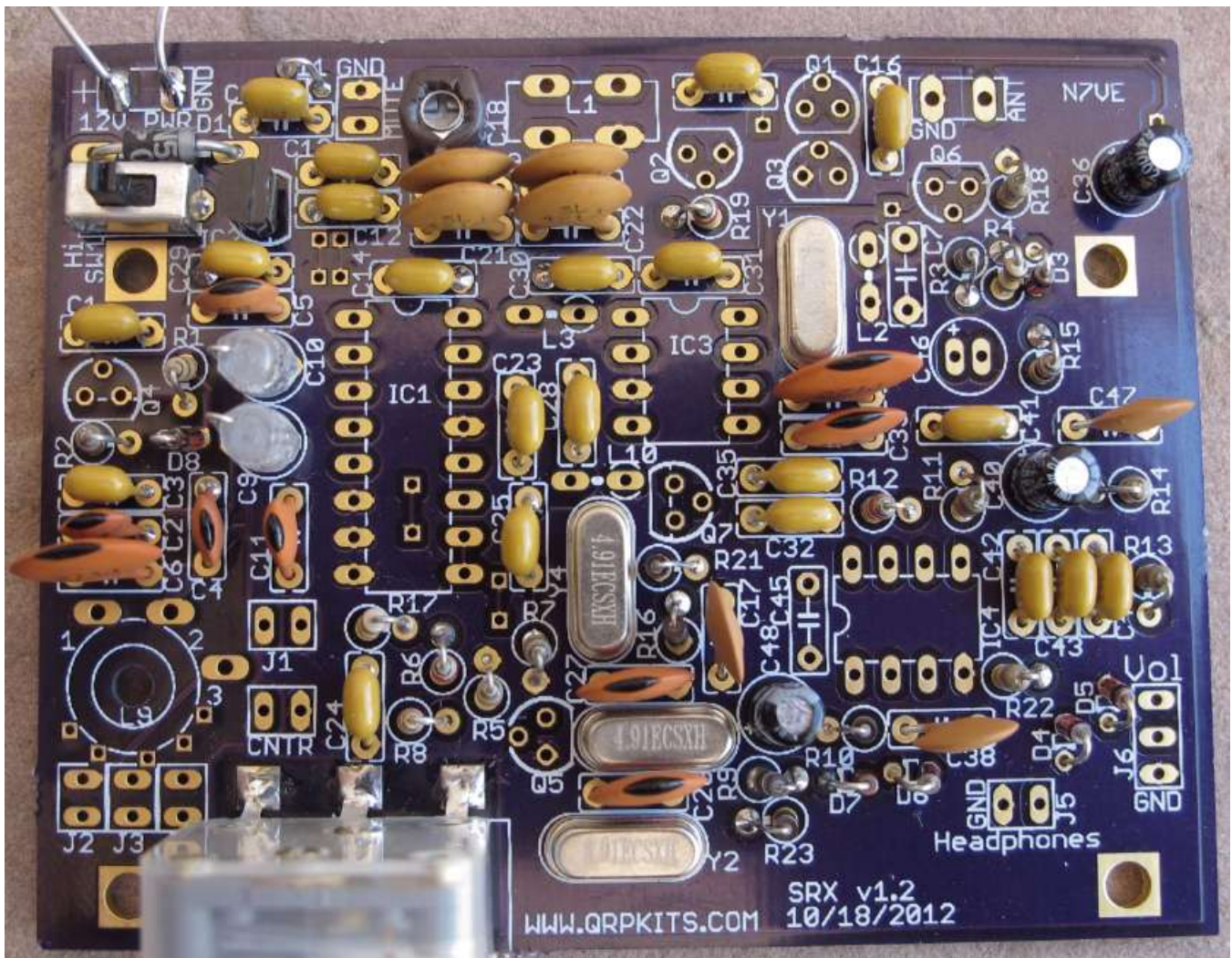

Figure 33. PCB with band specific Rs and Cs installed. 40m version shown.



## Installation of Inductors

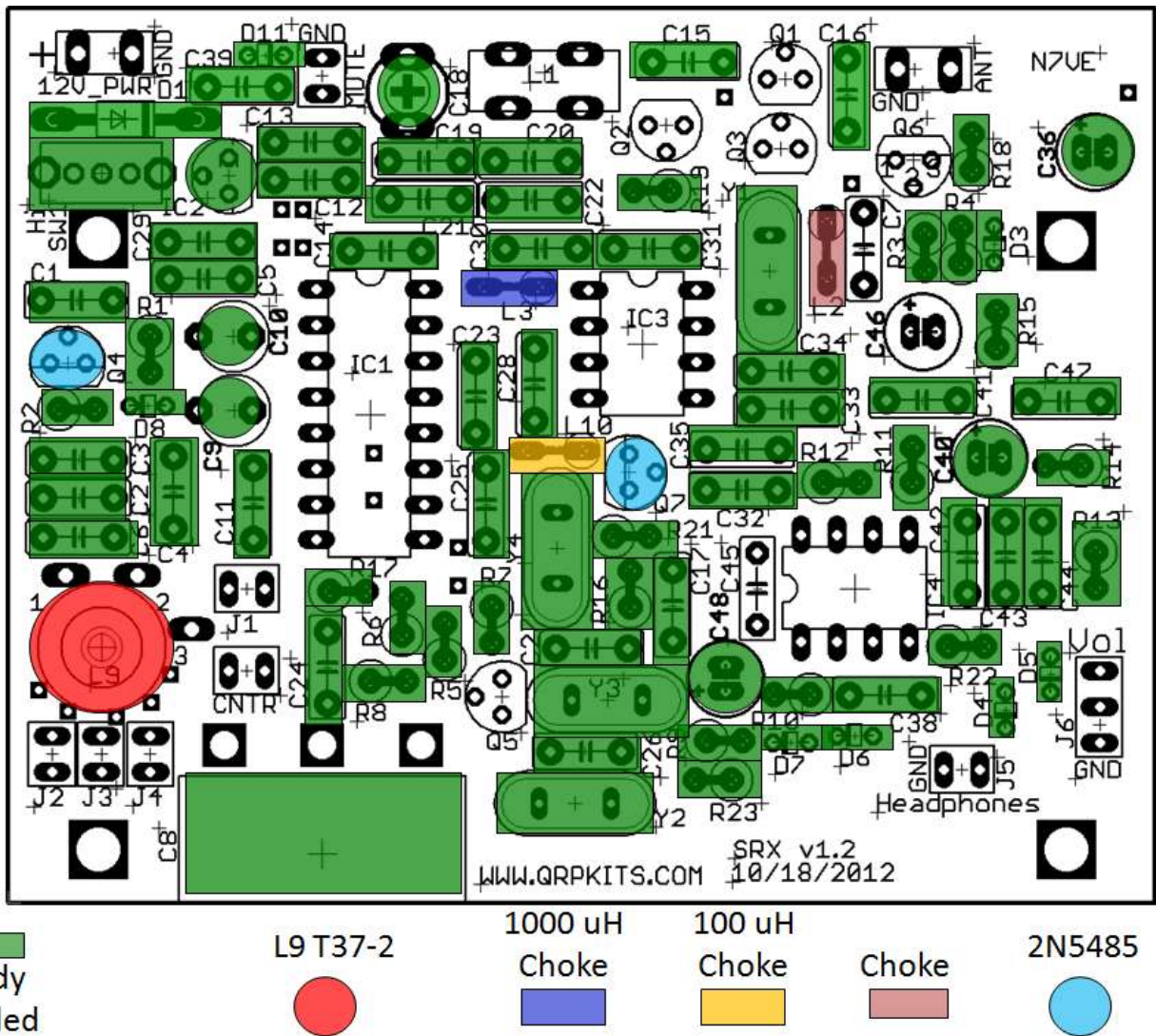

Figure 34. Overlay of PCB showing inductor placement (with JFETs)



Figure 35. JFET transistors, 1000/100 mH molded chokes, and VFO T37-2 core



Install 2N5485 □ Q1, □ Q7 – **Match flat side with board outline as shown above!** Keep the leads short on all devices – mount the transistor low to the board.



Figure 36. Lead forming and mounting of molded chokes L2, L3, and L10

Install 1000 mH caps (brown-black-red) □ L3 as shown above. **This is mounted on end with the body on the circle portion like a resistor.**

Install 100 mH caps (brown-black-brown) □ L10 as shown above.

Install band specific molded choke □ L2 as shown above.

**30m:** 10 uH (brown-black-brown)

**40m:** 33 uH (orange-orange-brown)

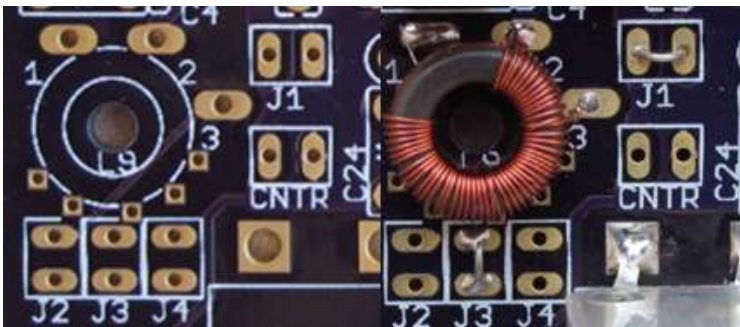

Figure 37. Band specific jumpers installed. 40m jumpers shown.

Install band specific jumpers as shown above:

**30m:** Using a lead scrap, bend into a “U” form and insert into □ J2 and □ J4

**40m:** Using a lead scrap, bend into a “U” form and insert into □ J1 and □ J3

## Instructions for winding inductors

The first inductor to be wound will be L9. The toroid core (T37-2) **has a red color**. It is very important to use the **right number of turns!** We will wind and install L9 first and will illustrate how to count the number of turns.

Cut xx” of green # 32 gauge wire. The number of turns used depends on the band the kit is being built for. The VFO coil is tapped. This means that a certain number of turns of wire will be wound, a wire loop for a tap will be formed, and then a second set of windings will be added.

**30m:** 10 turns - tap - then 31 more turns; 41 turns in total

**40m:** 13 turns - tap - then 39 more turns; 52 turns in total

Cut 28 inches of the # 32 wire. This is the thinner of the two wire types provided (#28 and #32 gauge). The first turn is placed through the core from the bottom as shown below. Hold the short end on the bottom, with the long end of the wire out the top of the core as shown below:



Figure 38. VFO coil L9. 40m version shown.

Above shows the winding sequence for a 40m VFO coil 10 turn coil. On the “13 turn” picture, you can count 13 turns on the inside of the coil, but only 12 on the outside. ***It is the inside turns that counts!*** I always double check by ***counting the outside turns and add 1***. ***Add turns to the coil counter-clockwise with each new turn coming in from the bottom side.*** Look closely at the 13 turn picture and you can count **13** turns on the **inside** of the core and **12** turns on the **outside**.  $12 + 1 = 13$ .

***Double check all the coils you wind for the right number of turns!***

Next the leads need to be trimmed and stripped. The enamel wire used in this kit is special in that it strips more easily than normal with heat. I simply use a blob of solder on the end of the iron and start from the cut end of the wire, burning off insulation and working towards the core edge. The burnt enamel fowls the solder, so I keep adding fresh solder as I go.

***It is very important that the twisted wire portion of the tap be properly soldered together.*** The #1 failure in kits can be traced to not properly stripping the leads of the toroid inductors. Use an ohm meter to check from the “start” wire to the “end” wire to make sure the “tap” wires are properly soldered together.

Install VFO inductor □ L9 using a red T37-2 toroid core. ***The two ends of the coil L9 connect to pads 1 and 2 while the tap connects to pad 3 as shown below.*** The connection to pin 1 should be temporarily soldered to the ***top side of the pad***, while the other two wires (2 and 3) should be soldered through the holes. This is because the frequency of the VFO will likely be too low, and turns will need to be removed from the coil on the pad 1 side and soldering to the top of pad 1 will make that easier.

□ Check L9 to make sure it has good solder contact: Use an ohm meter and make sure there is a short (i.e., zero ohms) between the pads 1, 2, and 3 that L9 is connected to.

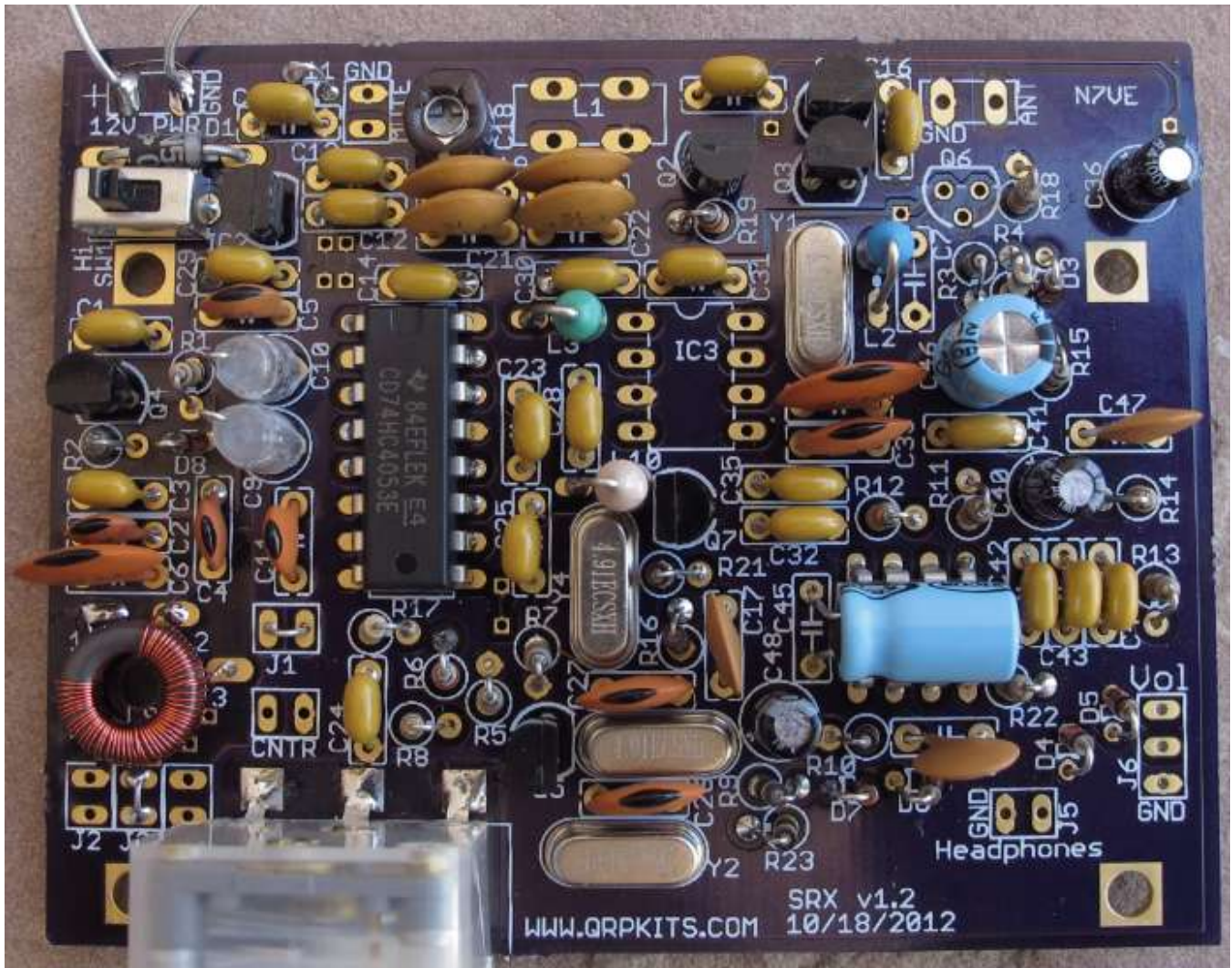

Figure 39. PCB with Inductors (and JFETs) installed

□ **Quick test # 2:** Connect 12v to the 12v input power leads. The current drain in this stage is roughly 8.5 mA. This number is not precise. However, if the current drain is a lot higher (like 15 mA), there is probably a problem that needs to be resolved first before moving on to the next stage.

*Disconnect the 12v when done.*



*Installation of misc items, part #1*

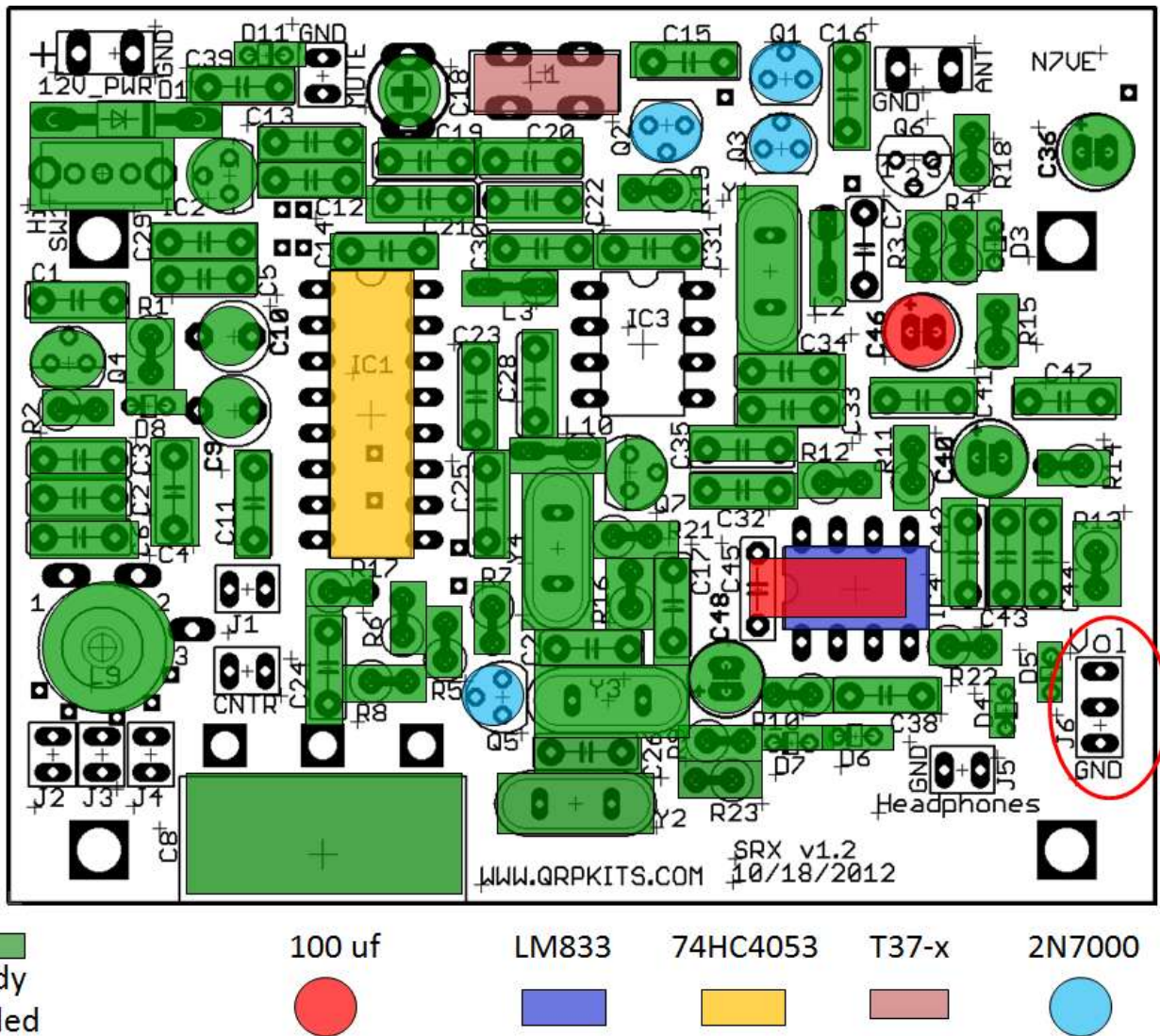

Figure 40. Overlay of the installation of misc items, part 1

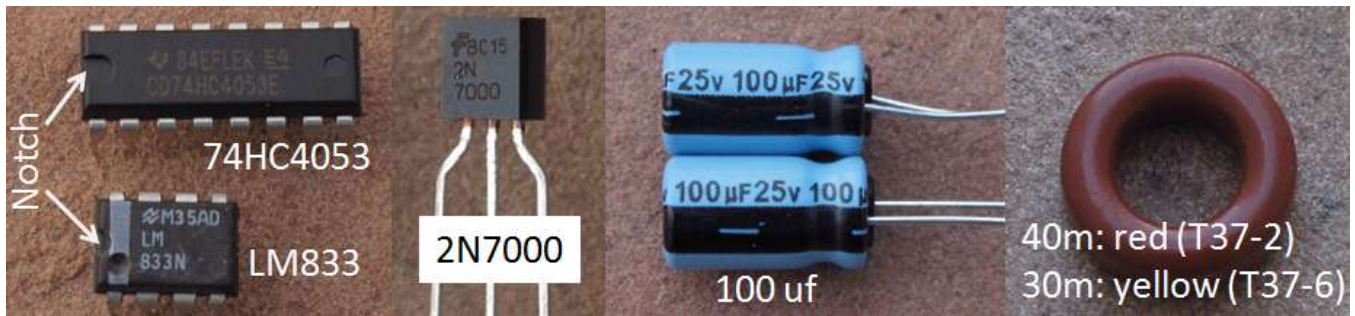

Figure 41. Picture of parts installed this in this section

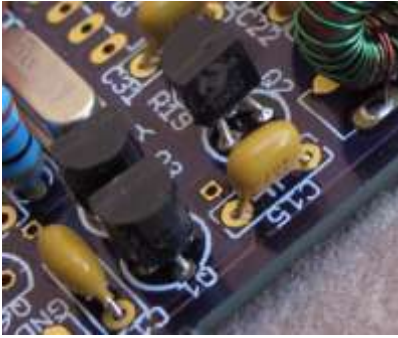

Figure 42. Keep all transistors close to the PCB (short leads!)

Install 2N7000 transistors □ Q1, □ Q2, □ Q3, □ Q5 *Keep all transistors low to the PCB with short leads as shown below. Transistor flat side must match PCB layout!*

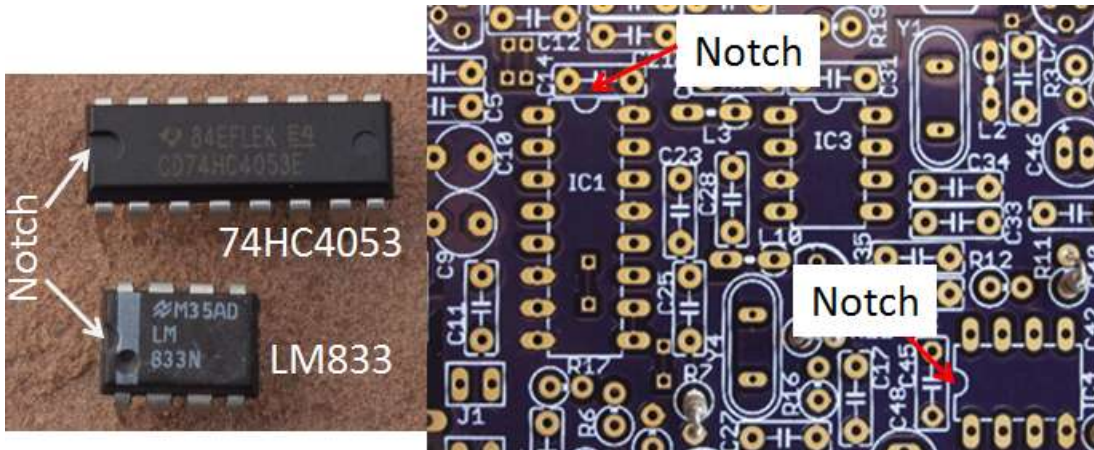

Figure 43. Notches on ICs line with outline on the PCB

Install 74HC4053 □ IC1 Make sure the IC notch lines up with the notch on the PCB as shown above.

Install LM833 □ IC4 Make sure the IC notch lines up with the notch on the PCB as shown above.

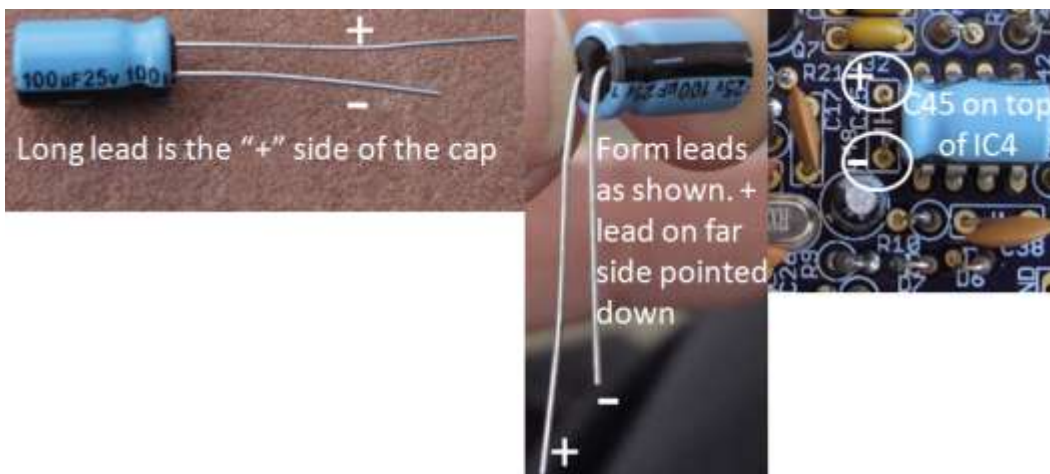

Figure 44. Lead forming for C45



Install 100 uf cap □ C45 with the leads formed as shown above on top of IC4 (LM833) also as shown.

Install 100 uf cap □ C46 **Make sure the longer “+” lead goes through the “+” hole on the board.**

Wind L1, a two winding resonate input RF transformer. The core type used for this transformer depends on the band used.

**40m:** A red T37-2 toroid core is used

**30m:** A yellow T37-6 toroid core is used

Likewise, the windings are band specific also. Cut 18” of #28 (the thicker wire) for the primary winding, 5” of #32 (the thinner wire) for the secondary winding.

**40m:** 29 turns primary (#28 larger gauge wire), 3 turns secondary (#32 smaller gauge wire)

**30m:** 22 turns primary (#28 larger gauge wire), 2 turns secondary (#32 smaller gauge wire)

The exact number of turns is very important! Please verify the right number of turns. The construction of L1 is shown below. The primary winding is wrapped first (**40m:** 29T, **30m:**22 T). In this case the last lead wrap should end as the same point the other lead started as these two leads will be inserted as a pair into the board. The secondary winding is wrapped **in between** the windings of the primary as shown.

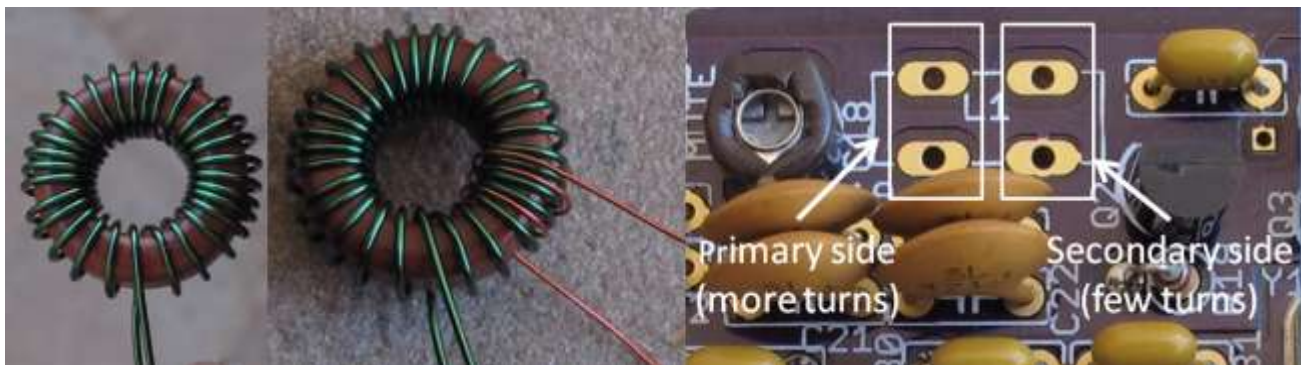

Figure 45. L1 transformer. 40m shown: 29T primary, 3T secondary

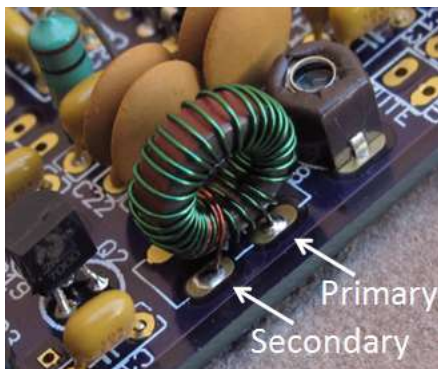

Figure 46. Primary and secondary winding connections of L1 to the board shown. 40m shown.



- Install L1 – double check for the right number of turns for the band used (**40m**: 29T/3T, **30m**: 22T/2T) Make sure to strip the leads up to the edge of the core as was done with L1.
- Check L1 to make sure it has good solder contact: Use an ohm meter and make sure there is a short (i.e., zero ohms) between the two primary winding pads, and between the two secondary winding pads.

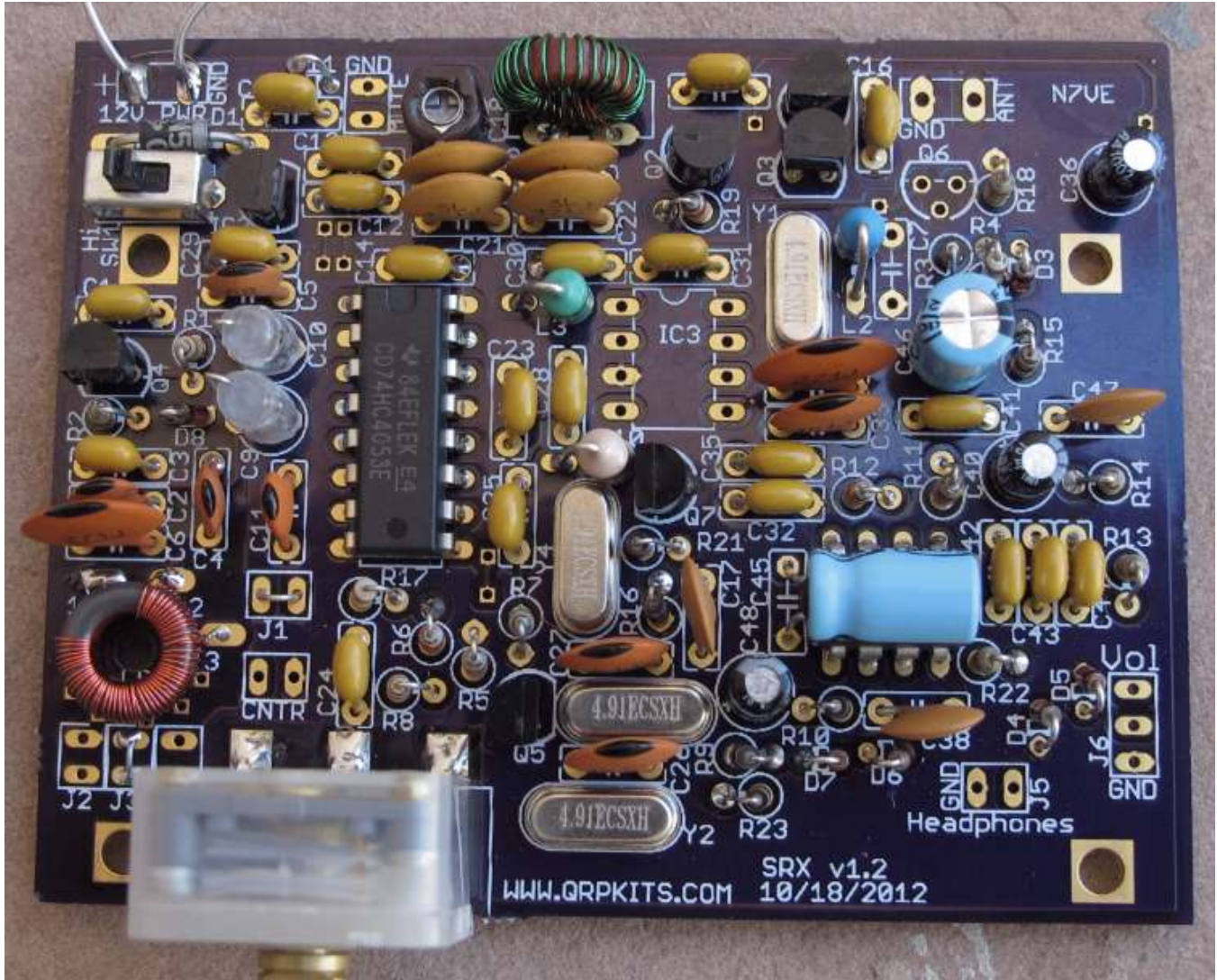

Figure 47. Board with misc items part # 1 installed.



**Figure 48. Temporary installation of volume pot and headphone jack for testing**

Temporarily connect the volume control pot using some scrap leads as shown above. Next add the headphone jack to that using more scrap leads as shown above. We will keep this arrangement until the board is mounted in the chassis.

**□ Quick test # 3:** Connect 12v to the 12v input power leads. The current drain in this stage is roughly 13 mA. This number is not precise. However, if the current drain is a lot higher (like 20 mA), there is probably a problem that needs to be resolved first before moving on to the next stage.

**□ Quick test # 4:** Connect headphones to the temporary headphone jack. With power applied and the volume control turned all the way up, hiss ought to be heard. Touching R9 or R23 with a damp finger (near the crystals and the front of the board) should produce a good 60 Hz “hum” to the headphones.

***Disconnect the 12v when done.***



*Installation of misc items, part #2*

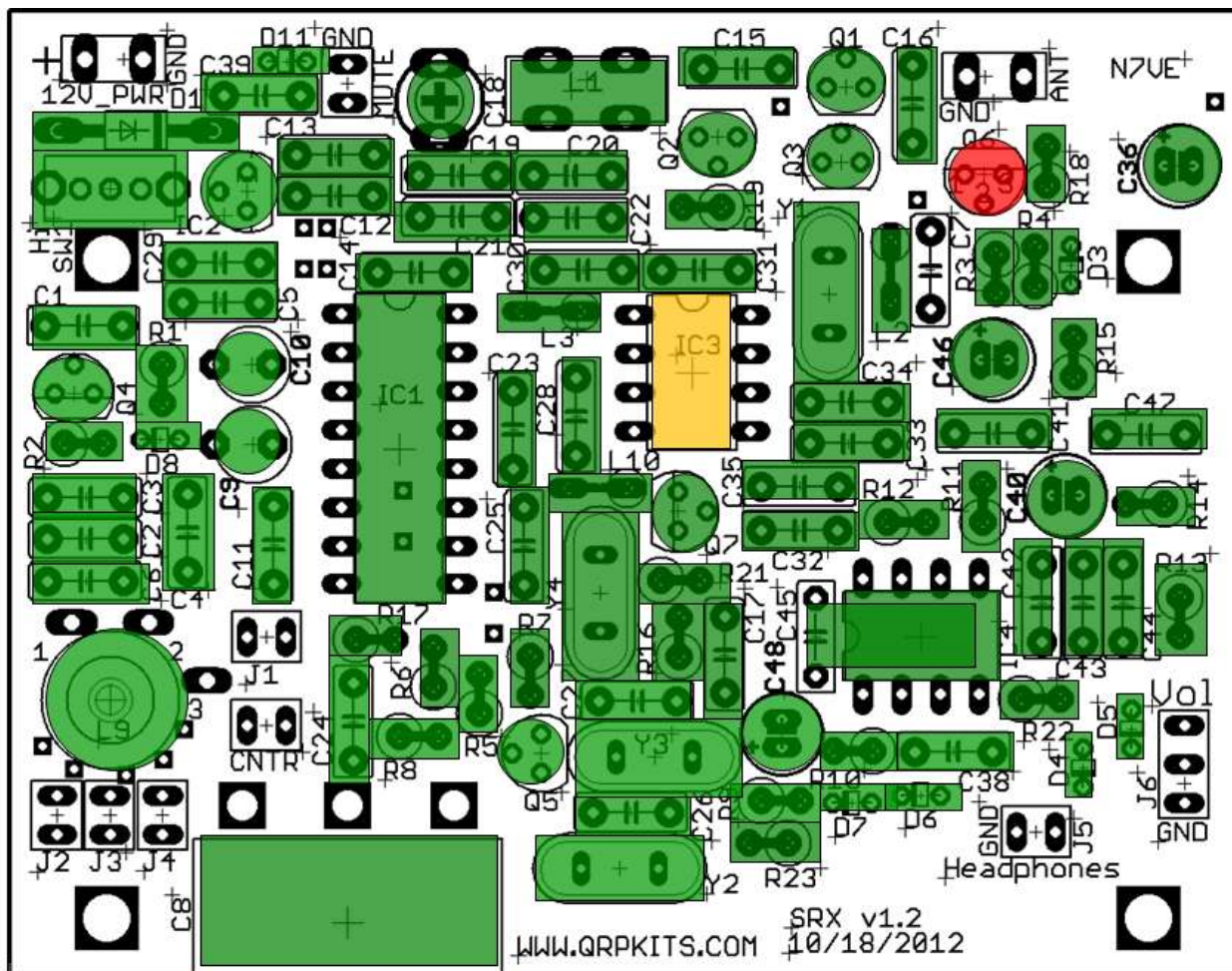

  
 Already  
 Installed

2N3904



NE602



Figure 49. Overlay showing the last board mounted parts

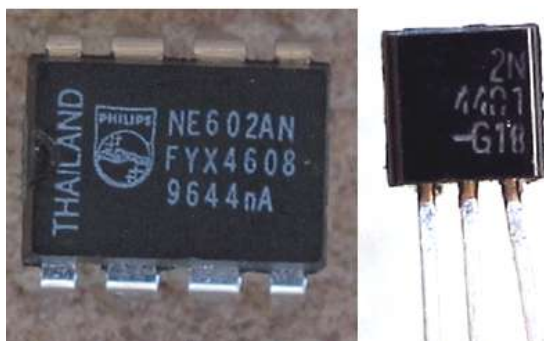

Figure 50. NE602 and 2N4401 parts shown



Install 2N4401 transistor □ Q6 *Keep all transistors low to the PCB with short leads. Transistor flat side must match PCB layout!*

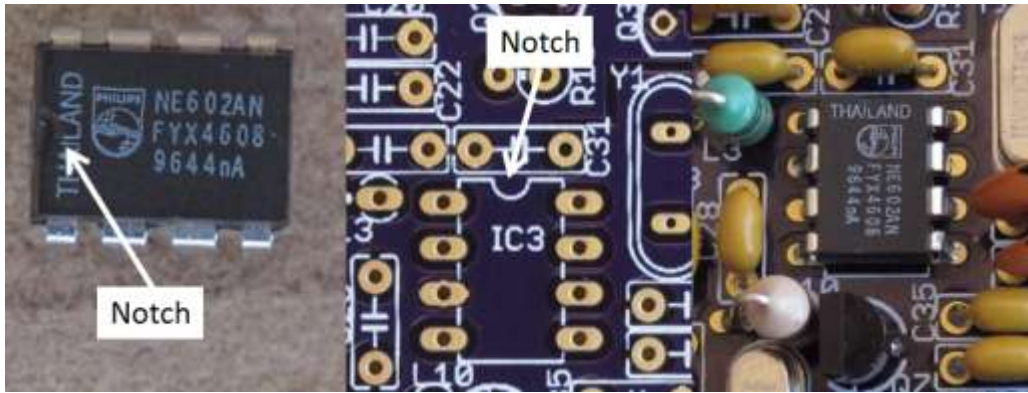

Figure 51. Installation of NE602. Match part and part outline notches.

Install NE602 □ IC3. Make sure the IC notch lines up with the notch on the PCB as shown above.



Figure 52. Completed receiver board

## *Installation decals on chassis*

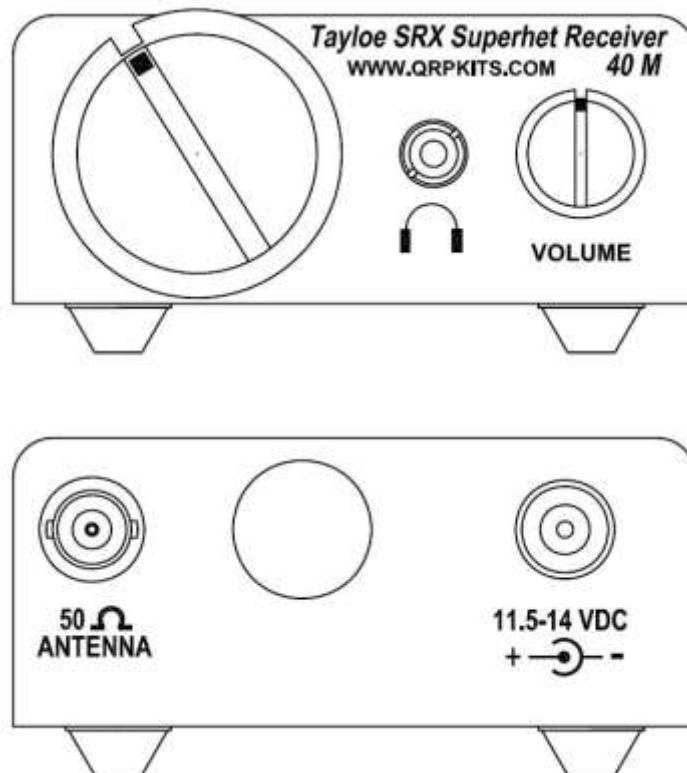

The decals are applied the same as model decals. Cut around each group of text or symbols you wish to apply. It doesn't have to be perfect as the background film is transparent. Apply the decals before you mount anything to the chassis. Use the above picture to get the correct spacing around the holes and cutouts, as it is very easy to do a great decal installation and have a portion covered up with a knob

**Thoroughly clean the surface of the panel to remove any oils or contamination. We have found that moving the decals into position on bare aluminum chassis is difficult, due to the brushed surface, so we advise pre-coating the chassis with the Krylon clear before applying the decals, and then, after as well.**

Trim around the decal. After trimming, place the decal in a bowl of lukewarm water, with a small drop of dish soap to reduce the surface tension, for 10-15 seconds. Using tweezers, handle carefully to avoid tearing. Start to slide the decal off to the side of the backing paper, and place the unsupported edge of the decal close to the final location. Hold the edge of the decal against the panel, with your finger, and slide the paper out from under the decal. You can slide the decal around to the right position, as it will float slightly on the film of water. Use a knife point or something sharp to do this. When in position, hold the edge of the decal with your finger and gently squeegee excess water out from under the decal with a tissue or paper towel. Work from the center, to both sides. Remove any bubbles by blotting or wiping gently to the sides. Do this for each decal, and take your time. Allow to set overnight, or speed drying by placing near a fan for a few of hours. When dry, spray two **light** coats of matte finish, Krylon, clear to seal and protect the decals, and allow to dry in between coats. All decals come with two complete sets, in case you mess one up.

## Installation of receiver into chassis

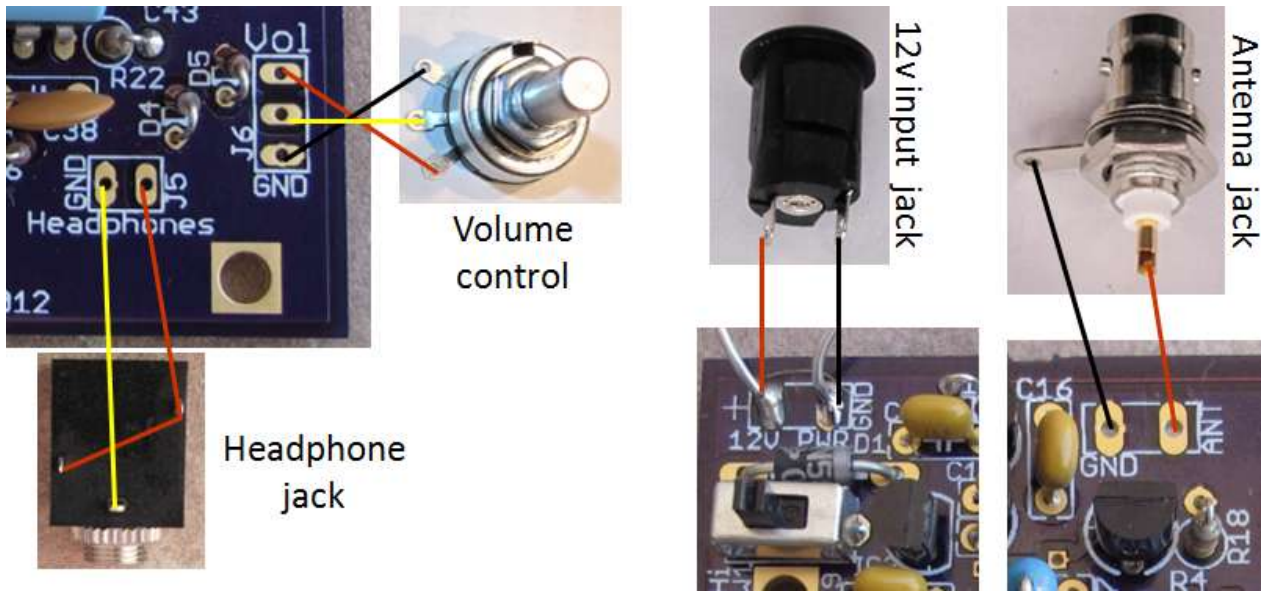

Figure 53. Visualization of PCB to chassis connections



Figure 54. Mount PCB in case using four 4-40 screws

Remove the temporary headphone, volume pot and power leads, then mount the PCB as shown in the chassis. It will only mount one way.





**Figure 55. Installation of main tuning hardware**

After the PCB is mounted in the chassis, add the hardware for the main tuning cap. The tuning shaft should be centered in the hole so that it does not touch the edges. After the tuning shaft hardware is added, check to see if the shaft turns smoothly with no drag. If drag is felt, the two mounting screws might be a bit too deep. If so, place 1 turn of the wire (#28 gauge shown here) under the screw to give the tuning cap a bit more room.

Finally, add the tuning knob. It should not be mounted flush with the case, but should have a slight gap so that it will turn without rubbing the case.



**Figure 56. Mounting of the headphone jack**

Mount the headphone jack to the front panel as shown. Do not install the volume control (shown above) until after the headphone jack is wired to the PCB. Install the shorting wire between the left and right side of the headphone jack if it is not still in place from the temporary installation. See above.



**Figure 57. Wiring of the headphone jack and volume control to the PCB**

Wire the headphone jack to the PCB as shown above using a scrap piece of enameled wire. This is a very low current connection, so the thinner #32 gauge wire can be used for this task.



**Figure 58. Volume control pot mounted to the front panel**

Mount the volume control to the front panel. Make sure the washer is on the inside of the case. Tighten the mounting nut and add the knob. Finally, wire the volume control to the PCB as shown above in the headphone picture. If in doubt, see the visualization diagrams at the beginning of this section.

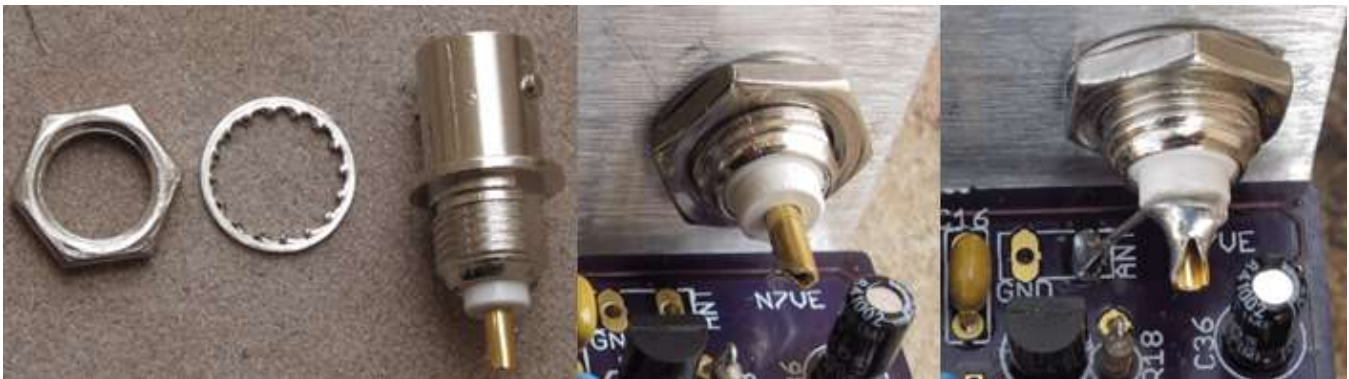

**Figure 59. Mounting of the antenna connector.**

The antenna connector is mounted as shown on the back panel. A lead scrap is used to connect the antenna connector center pin to the PCB. Ground connection to the antenna jack is provided via the PCB mounting screw and standoff near that connector so that a connection to the antenna “ground” pad is not really needed.

The center hole in the real panel is not used. A hole plug has been provided to fill that hole.

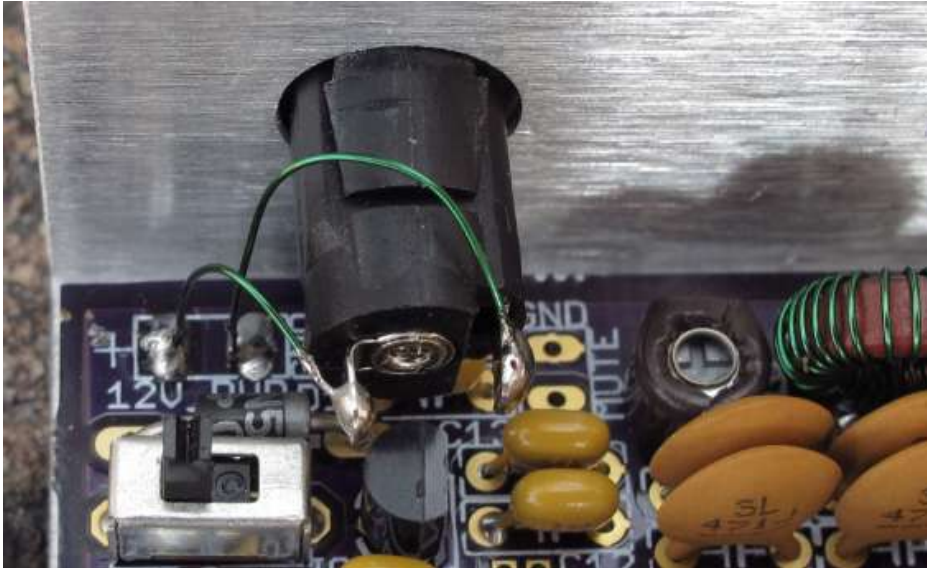

**Figure 60. Connection of the 12v power jack to the PCB.**

Mount the 12v power jack and connect to the PCB as shown using scrap #28 gauge wire. As shown above, the center power lug goes to the “+” side of the 12v power input, while the outer terminal goes to the ground side.

The last step is to add the four rubber “feet” to the bottom of the case.

The receiver is now fully assembled. The next phase is tuning up the front end band pass filter and setting the VFO on frequency.



**Figure 61. Front and rear panel views with the mounted hardware (Headphones not included).**



## VFO alignment

In order to set the VFO frequency, set the main tuning to the low frequency with the main knob set **full counter clockwise** as shown below. Next set the band segment switch to the lower frequency segment (**slide set away from the board edge**) as shown below. Between these two settings, the VFO will be set to the lowest received frequency. In the end, we want this to be 7.000 MHz for 40m and 10.100 for 30m.



Figure 62. Picture main tune set to the lowest frequency, band segment switch set to low freq

The crystals used on 40m are 4.915 MHz crystals. Thus the VFO needs to set to 7-4.915 or **2.085 MHz for 40m**. For 30m, 7.37 MHz crystals are used so the VFO needs to be set to 10.1-7.37 or **2.73 MHz for 30m**.

There are three types of VFO tuning that will be done:

- Removing turns from L9.
- Compressing or expanding the turns on L9
- Using the trimmers on the back of the main tuning capacitor

First, removing turns from the VFO coil L9 provides the initial rough tuning. The coil has been designed with a couple turns to many.

Secondly, the VFO coil turns are wound “shoulder to shoulder” as tightly as they can. This leaves some spare coil space unused. Expanding the coil turns will raise the frequency by roughly as much as removing one turn. This is used for VFO fine tuning. Playing with expanding/compressing the winding can get the receiver very close.

Finally, there are trimmers on the back of the main tuning cap which provide about 2 KHz of total tuning range. These can be used to tweak the VFO right where it should be.

A frequency counter can be used to set the VFO to the correct frequency. Connect the counter to the “CNTR” jack as shown below. This point has a 2.2 pf coupling cap. Attaching the frequency counter to this point will make the frequency a bit low, a bit under less than 1 KHz. After the frequency counter is removed, the final received frequency can be touched up by a combination of expanding/compressing the L9 coil and adjusting the main tune trimmers.

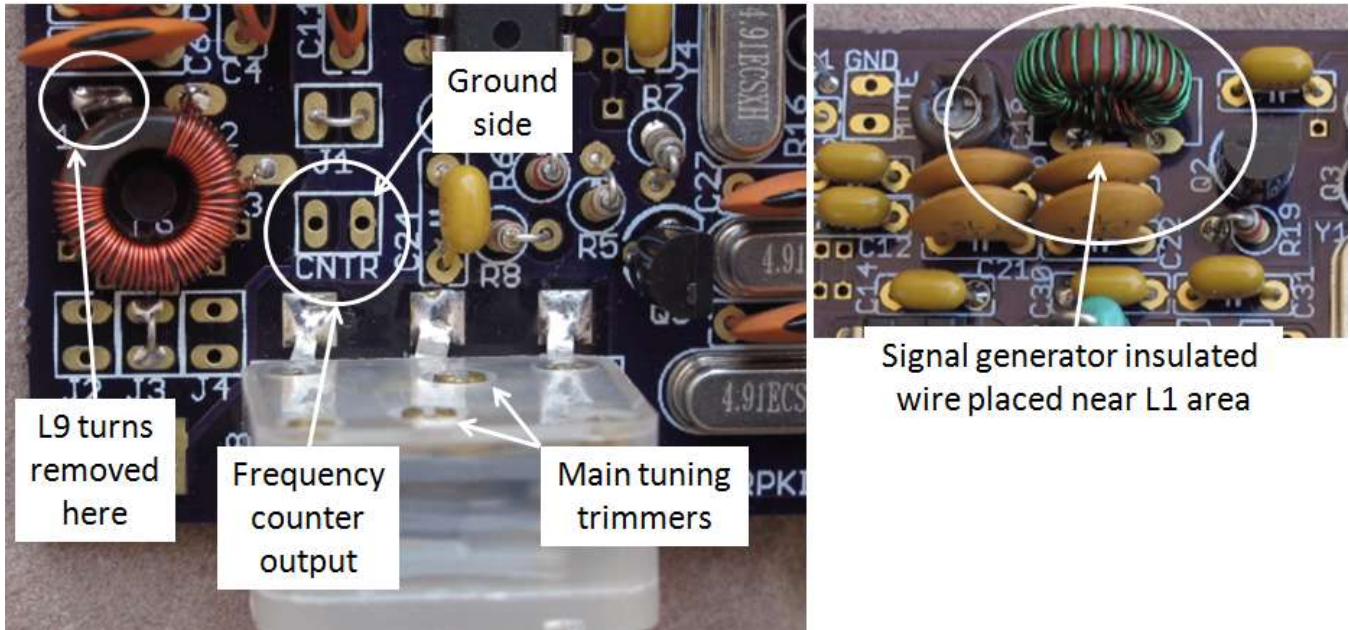

Figure 63. View of VFO area and L1 front end area

The simplest way to set the VFO on frequency is to use a signal generator, like a DDS VFO, and use the generator to feed an insulated wire that is placed close to L1. If an actual signal generator is used, set it to a relatively large signal level such as -40 dBm. Now sweep the signal generator as listed below until the signal generator signal is heard.

In either case, if a frequency counter or a signal generator is used the following step should be used to set the VFO. **Note that the VFO coil turns is deliberately set to start the VFO frequency low** since it is easier to remove turns than to add one back. If you are using the signal generator method, you may need to search around a bit depending on exactly how many turns have actually been placed on L9. It is easy to be off by one or two turns either way.

40m: Sweep 6.6 to 7.1 MHz. My receiver 40m started at 6.914 MHz while having L9 two turns short as verified by counting turns in the pictures of the VFO coil.

30m: Sweep 9.5 to 10.2 MHz

The VFO should come up too low in frequency. The VFO is course tuned by removing turns from the 39T (40m) or 31T (30m) side of L9. This Each turn removed raises the frequency by about 30 kHz (40m) or 60 kHz (30m). Expect to remove 2 to 4 turns (perhaps more) to get the VFO on frequency.



The goal in removing turns (rough tuning) is to get within one turn of the final frequency. *I.e., you always want to end up low in frequency compared to the desired setting.*

Assume 30 kHz (40m) or 60 kHz (30m) frequency change per turn removed and that the receiver is 150 kHz low. This 150 kHz difference means that removing 5 turns (40m) and 2 turns (30m) is needed to get to less than 1 turn low in frequency. *Don't take all these turns off at the same time.* Start by removing one (if close) or two turns (if far away) at a time. These extra turns are removed from L9 at the end (pad "1") indicated by the figure above. This lead that should have been soldered to the top of its pad to make it easier to unsolder and reattach when finished. Remove the one or two turns, cut off the excess wire, tin the wire and re-solder it to the top of the pad. Now double check the received frequency either using a frequency counter or a signal generator, sweeping the signal generator around until it is again heard in the receiver. Each time a turn or two is removed, double check the frequency shift and use that to estimate the next round of turns removal (if needed). Each time turns are removed, cut off the extra wire, re-tin the lead, and solder it down to the top of pad 1 of L9. With the turns on L9 as compressed as possible, we need to get within *less than one turn* of the final frequency. *Again, we need to end up this "rough tune" step being low in frequency.*

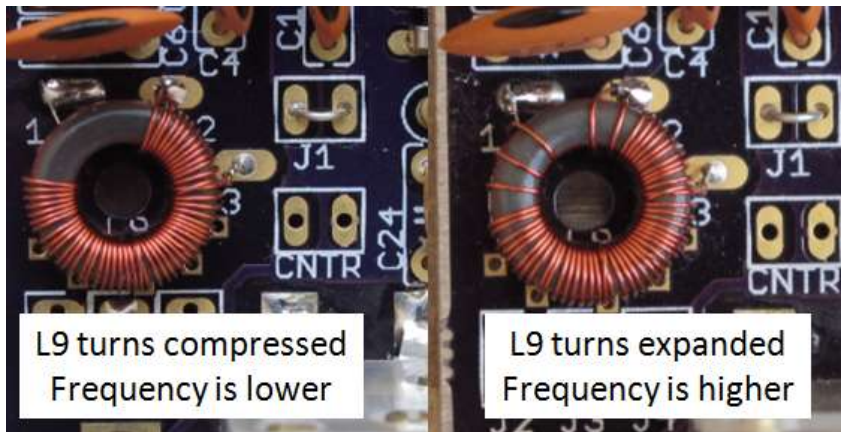

Figure 64. Picture of L9 with compressed and expanded windings for VFO fine tuning

When turns have been removed to less than one turn lower than the final frequency, the next step is coil compression/expansion. L9 should have been wound with the turns "shoulder to shoulder" with no gaps between the turns. This creates a "bare core" gap from the start winding to the end winding (pad 1 and 2 on the PCB). When the turns are spread out to cover more of this "gap", the VFO frequency will increase. *Notice that it is not necessary to expand the turns evenly around core to increase the frequency.* See the pictured examples above.

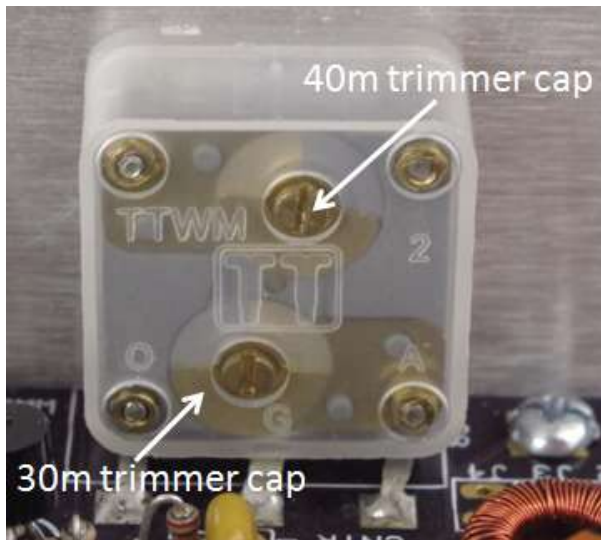

Figure 65. Trimmer caps on this particular polyvaricon

It is a bit difficult to get the edge frequency “right on” spreading and compressing the turns. There are trimmers on the back of the main tuning capacitor which has roughly a 2 KHz of total frequency shift which can be used to “fine tune” the final frequency if desired. The trimmer locations shown are for the specific polyvaricon tuning cap that was used in this build. The one you get might have a different configuration and you will need to experiment to see which one is used for the band you are building.

When the surface the receiver is bumped, a bit of “twang” might be heard in the receiver due to some vibration of L9. If this is the case, it might be desirable to use a **\*\*small\*\*** amount of **hot candle wax or hot glue** to stick the coil to the surface of the PCB. An alternative might also be to use a **nylon 4-40 screw (1”), a nylon washer, and a nylon nut**. 6-32 nylon hardware will work also. These nylon components can be found at Ace Hardware or other hardware stores. These additions will shift the VFO frequency, so it is not recommended to do this unless you want to go through another round of VFO adjustments.

**Never use glues to cement L9 into place!** Some glues will ruin the operation of the VFO (like Gorilla Glue, Super glue, or J B Weld are known problems). **Do not risk this.** Please stick with candle wax, hot glue, or nylon hardware to stabilize L9 if it does have a vibration problem.

**A note on VFO stability.** For best drift performance, I have found that VFOs need to be “broken in” for best VFO stability. I suggest leaving the rig on continuously for at least three days to accomplish this.

Since this is designed to be inexpensive (yet high performance!), the chassis is left open. Air conditioning (summer) or heating (winter) drafts may cause drifting. If this is a problem a paper top “shell” can be formed over the receiver to protect the VFO from drafts. You will need to cut a square notch in the shell if you need to get to the band segment switch.

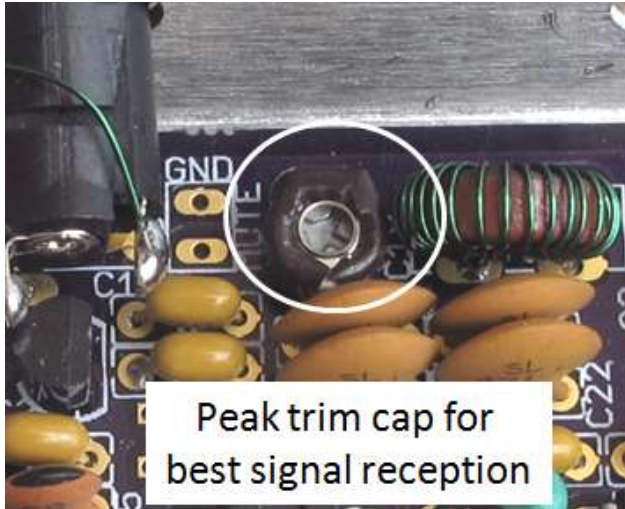
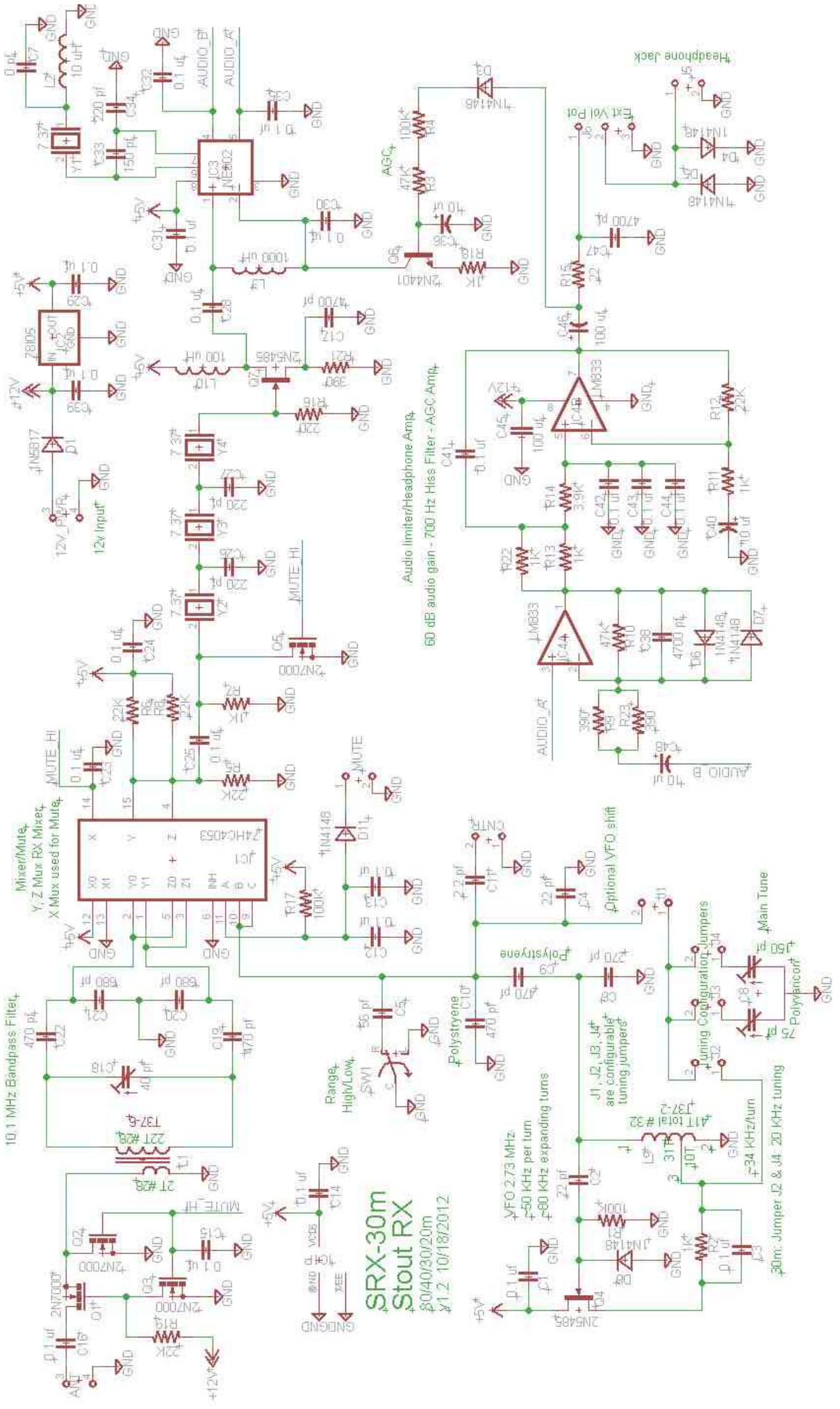

**Figure 66. Trim cap to peak receiver front end**

The only thing left to do is to connect an antenna (or weak signal generator) and peak the receiver input (trim cap C18) for the best signal reception. As both sides of this cap is “hot”, use very short, insulated screw driver. A tuning tool is best for this purpose. A normal screw driver will detune the circuit and potentially get a false peak.

At this point in time, the kit is done.





**SRX-30m Stout RX**  
 8040/30/20m  
 X1.2 10/18/2012

Audio limiter/Headphone Amp  
 60 dB audio gain - 700 Hz Hiss Filter - AGC Amp

Optional VFO shift

30m: Jumper J2 & J4 - 20 KHz tuning

